

# COOK PORTABLE WAREHOUSES

100 DOUGLAS STREET  
VALDOSTA, GA 31601

## GARDEN SHED FOR THE INTERNATIONAL BUILDING CODE

### DESIGN CRITERIA

1. WIND VELOCITY (V-ULT) 160 M.P.H. i
2. BUILDING CATEGORY C
3. WIND EXPOSURE C
4. INT. PRESSURE COEFFICIENT  $\pm 0.18$
5. ENCLOSURE CLASSIFICATION ENCLOSED
6. BASED ON HEIGHT 15 FEET
7. OVERHANG NO
8. FLOOR DESIGN LIVE LOAD 40 PSF
- FLOOR DESIGN DEAD LOAD 4 PSF
9. ROOF DESIGN LIVE LOAD 20 PSF
- ROOF DESIGN DEAD LOAD 7 PSF
10. WALL DESIGN DEAD LOAD 9 PSF
11. CONSTRUCTION TYPE  $\bar{V}$  B
12. BUILDING OCCUPANCY = U
13. FIRE RATING EXT. WALLS O
14. ALLOWABLE NUMBER OF FLOORS I
15. THE CONTRACTOR/MANUFACTURER MUST COMPLY WITH THE FOLLOWING CODES AND ALL OF THESE AMENDMENTS/SUPPLEMENTS:  
- INTERNATIONAL BUILDING CODE, BUILDING - 2012

MISSISSIPPI PLANT  
132 CENTRAL INDUSTRIAL ROW  
PERVIS, MISSISSIPPI 39475

TEXAS PLANT  
1398 HWY 95 NORTH  
BASTROP, TX 78602

GEORGIA PLANT  
100 DOUGLAS STREET  
VALDOSTA, GEORGIA 31601

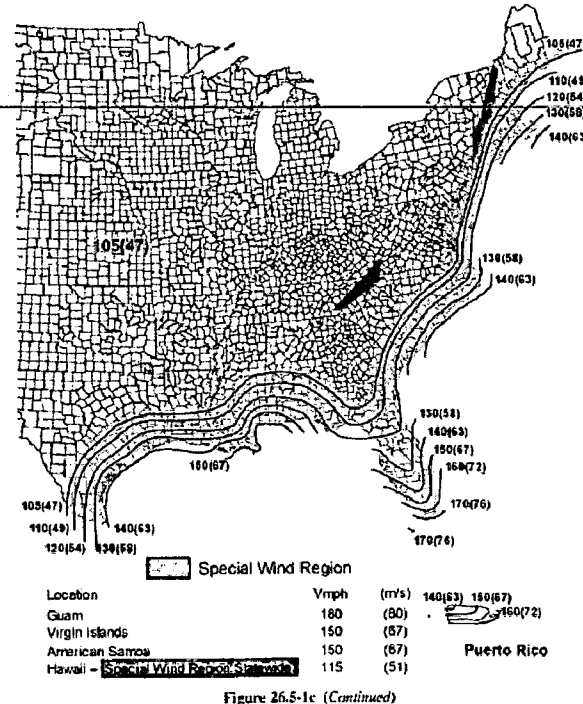

THESE PLANS HAVE BEEN DESIGNED TO MEET THE STRUCTURAL REQUIREMENTS AS SET FORTH IN THE INTERNATIONAL RESIDENTIAL CODE FOR A CATEGORY II BUILDING IN AN AREA OF EXPOSURE C. THE CURRENT DESIGN FOR THE ULTIMATE WIND SPEED AS REQUIRED IN THE IRC FOR THE STATE OF TEXAS COASTAL BUILDINGS SHALL NOT BE LESS THAN 150 MPH.

SHEET LIST	
SHEET NUMBER	SHEET TITLE
C-1	COVER SHEET
C-2	WIND LOADING
C-3	NOTES
C-4	FASTENING SCHEDULE
C-5	FASTENING SCHEDULE
C-6	FASTENING SCHEDULE
A-1	FLOOR DECK & FRAMING PLANS
A-2	SHEARWALL TABLE
A-3	EXTERIOR ELEVATIONS
A-4	FRAMING ELEVATIONS
A-5	FRAMING ELEVATIONS
A-6	FRAMING ELEVATIONS
A-7	SECTION & DETAIL
A-8	ROOF SECTIONS
A-9	DETAILS
A-10	DETAILS
A-11	DETAILS
A-12	DETAILS

### AREA FOR APPROVAL STAMPS

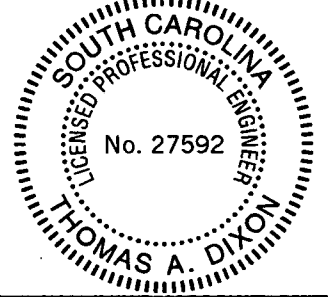

					BUILDING CODE
REV	BY	DATE	DESCRIPTION		

THESE PLANS WERE DESIGNED IN ACCORDANCE WITH THE 2012 INTERNATIONAL BUILDING CODE, BUILDING CATEGORY II, WIND SPEED OF 160 MPH.

**THOMAS A. DIXON, P.E.**

AL# 306371 MS# 19034 KS# 21198	DIXON ENGINEERING, INC.
SC# 27542 NC# 035485 GA# 034371	STRUCTURAL ENGINEERING AND INSPECTION - COA 8195
NV# 071936 TX# 104353 MD# 40905	10410 MAIN STREET
PA# 079009 VA# 045543	THONOTOSASSA, FL 33542
TN# 112761 FL# 34222	VOICE: 813-982-9885 FAX: 813-982-2306

**COOK PORTABLE WAREHOUSES**  
GARDEN SHED  
100 DOUGLAS STREET  
VALDOSTA, GA 31601  
PHONE: 1-229-241-8805

**COVER SHEET**

Professional Engineer stamp for Thomas A. Dixon, State of Mississippi, License No. 19034.

DATE:	03/27/12
DRAWN BY:	JDA/DGF
CHECKED BY:	TAD
SCALE:	AS NOTED
N.O. NO:	495-064

SHEET  
**C-1**  
1 OF 18

This drawing is the property of Dixon Engineering, Inc. Unless otherwise provided for by contract, or other written means, the contents of this drawing are confidential and shall not be transmitted to any other party except as agreed by Dixon Engineering, Inc. Copyright.

This drawing is the property of Dixon Engineering, Inc. Unless otherwise provided for by contract, or other written means, the contents of this drawing are confidential and shall not be transmitted to any other party except as agreed by Dixon Engineering, Inc. Copyright.

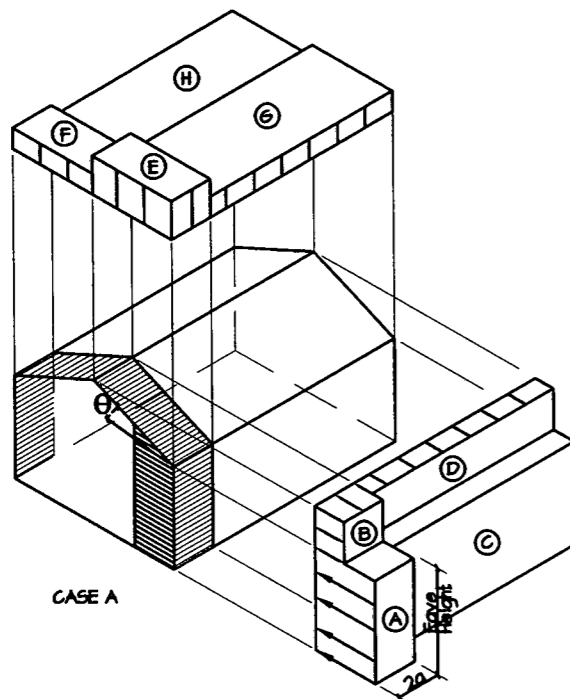

CASE A

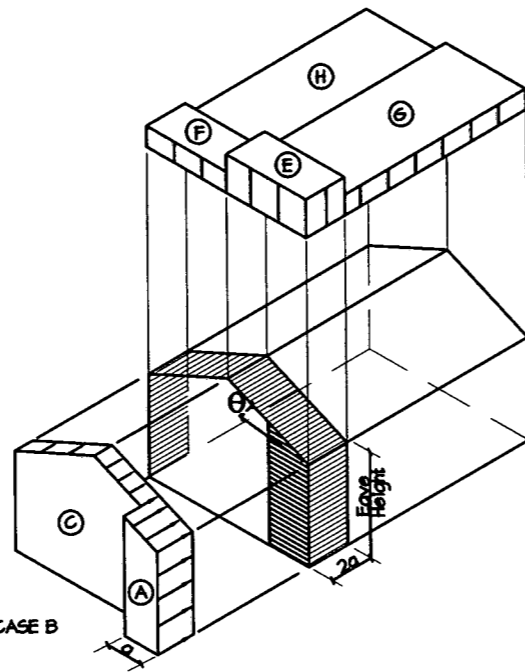

CASE B

WIND LOAD MAIN WIND FORCE PRESSURE DIAGRAMS

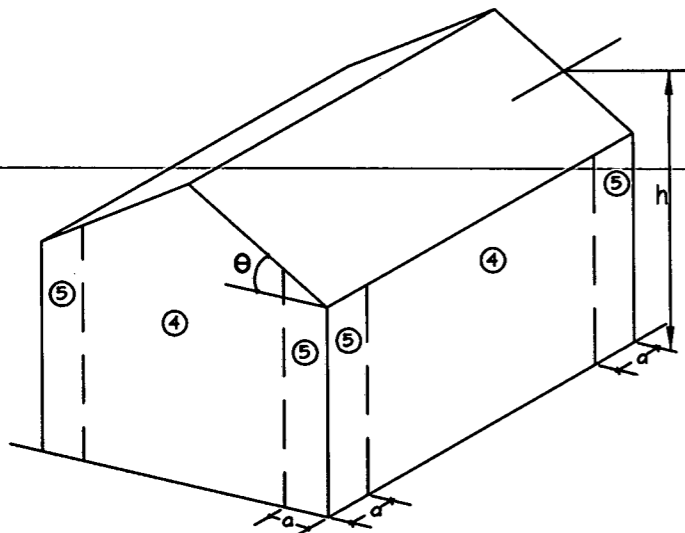

WIND LOAD COMPONENT AND CLADDING WALL PRESSURE DIAGRAM

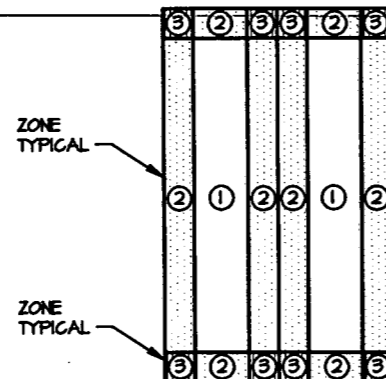

WIND LOAD COMPONENT AND CLADDING ROOF PRESSURE DIAGRAM

**BUILDING DATA ASCE 7-10 WIND**

WIND VELOCITY (Basic Wind Speed, 3 second gust) 160 mph INTERNAL PRESSURE COEFFICIENT: ± 0.18  
 BUILDING CATEGORY I HEIGHT & EXPOSURE ADJUSTMENT COEFFICIENT 1.21  
 ROOF ANGLE, θ (degrees) 7.27 degrees ROOF DEAD LOAD RESISTING UPLIFT (psf) 7  
 WIND EXPOSURE CATEGORY C

**DESIGN WIND LOADS - WINDOWS, DOORS, COMPONENTS AND CLADDING**

ZONE	AREA (SF)	ROOF			ZONE	AREA (SF)	WALLS		ZONE	AREA (SF)	ROOF OVERHANG	
		Positive	Negative	Net Uplift			Positive	Negative			Positive	Negative
1	10	32.1	-50.9	-43.9	4	10	55.8	-60.5	2	10	-103.9	
1	20	29.3	-49.6	-42.6	4	20	53.2	-58.0	2	20	-103.9	
1	50	25.5	-47.7	-40.7	4	50	49.6	-54.6	2	50	-103.9	
1	100	22.6	-46.2	-39.2	4	100	47.4	-52.2	2	100	-103.9	
2	10	32.1	-88.8	-81.8	4	500	41.5	-46.2	3	10	-174.7	
2	20	29.3	-81.7	-74.7	5	10	55.8	-74.7	3	20	-157.7	
2	50	25.5	-72.2	-65.2	5	20	53.2	-69.6	3	50	-135.2	
2	100	22.6	-65.2	-58.2	5	50	49.9	-62.9	3	100	-118.1	
3	10	32.1	-131.3	-124.3	5	100	47.4	-58.0				
3	20	29.3	-122.7	-115.7	5	500	41.5	-46.2				
3	50	25.5	-111.4	-104.4								
3	100	22.6	-103.0	-96.0								

- Notes:  
 1. For effective areas between those given above the load may be interpolated, otherwise use the load associated with the lower effective area.  
 2. Plus and minus signs signify pressures acting toward and away from the surfaces, respectively.  
 3. Pressures shown are applied normal to the surface.  
 4. Refer to pressure zone diagrams provided for corresponding zones.  
 5. Roof framing members shall be designed to resist the net uplift design pressures specified.  
 6. Roof coverings, finishes, etc. shall be designed for the full negative design pressure.  
 7. Design pressures shown shall be multiplied by its appropriate load case factor from article 2.4.1 of ASCE 7-10 when performing stress design on structural elements of building.

**DESIGN WIND LOADS - MWFRS METHOD 2 ENCLOSED BUILDINGS H ≤ 60'**

BASIC WIND SPEED (mph)	ROOF ANGLE (DEGREES)	LOAD CASE	ZONES								ROOF OVERHANG	
			HORIZONTAL PRESSURES				VERTICAL PRESSURES				E <sub>OH</sub>	G <sub>OH</sub>
			A	B	C	D	E	F	G	H	E <sub>OH</sub>	G <sub>OH</sub>
0-5	1		-49.1	-25.5	32.5	-15.1	-59.0	-33.5	-41.1	-26.0	-82.6	-64.7
10	1		55.4	-23.0	36.8	-13.4	-59.0	-36.1	-41.1	-27.7	-82.6	-64.7
15	1		61.7	-20.4	41.1	-11.6	-59.0	-38.6	-41.1	-29.4	-82.6	-64.7
20	1		68.0	-17.9	45.4	-9.9	-59.0	-41.1	-41.1	-31.2	-82.6	-64.7
25	1		61.6	9.9	44.6	10.2	-27.3	-37.3	-19.8	-30.0	-50.9	-43.4
25	2		0.0	0.0	0.0	0.0	-10.4	-20.3	-2.8	-12.9	0.0	0.0
30 to 45	1		55.3	37.8	43.9	30.3	4.2	-33.5	1.5	-28.8	-19.4	-22.1
30 to 45	2		55.3	37.8	43.9	30.3	21.3	-16.6	18.4	-11.9	-19.4	-22.1

- Notes:  
 1. For effective areas between those given above the load may be interpolated, otherwise use the load associated with the lower effective area.  
 2. The load patterns shown shall be applied to each corner of the building in turn as the reference corner. (See Figure 28.4-1)  
 3. For the design of the Case B MWFRS use θ = 0°.  
 4. Plus and minus signs signify pressures acting toward and away from the projected surfaces, respectively.  
 5. Where zone E or G falls on a roof overhang on the windward side of the building, use E<sub>OH</sub> and G<sub>OH</sub> for the pressure on the horizontal projection of the overhang. Overhangs on the leeward and side edges shall have the basic zone pressure applied.

AREA FOR APPROVAL STAMPS



REV	BY	DATE	DESCRIPTION

THESE PLANS WERE DESIGNED IN ACCORDANCE WITH THE 2012 INTERNATIONAL BUILDING CODE, BUILDING FOR A WIND SPEED SECOND GUST OF 160 MPH.

**THOMAS A. DIXON, P.E.**

AL# 30637 MS# 19034 KS# 21198  
 SC# 27592 NC# 035985 GA# 034371  
 MV# 071936 TX# 104353 MD# 40905  
 PA# 079009 VA# 045543  
 TN# 112761 FL# 34222  
 DIXON ENGINEERING, INC.  
 STRUCTURAL ENGINEERING AND INSPECTION - COA 8195  
 10410 MAIN STREET  
 THONOTOSASSA, FL 33542  
 VOICE: 813-982-9885 FAX: 813-982-2306

**COOK PORTABLE WAREHOUSES**

GARDEN SHED  
 100 DOUGLAS STREET  
 VALDOSTA, GA 31601  
 PHONE: 1-229-241-8805

**WIND LOADING**

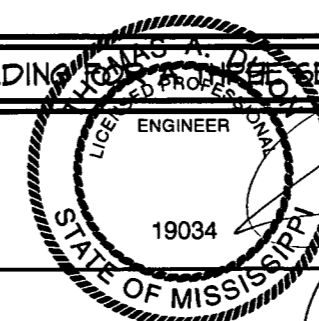

DATE: 03/21/12  
 DRAWN BY: JDA/DGF  
 CHECKED BY: TAD  
 SCALE: AS NOTED  
 W.O. NO.: 495-064

SHEET  
**C-2**  
 2 OF 18

**GENERAL NOTES**

THIS STRUCTURE WAS DESIGNED IN ACCORDANCE WITH THE 2012 INTERNATIONAL BUILDING CODE, BUILDING (I.B.C.)  
 ALL MATERIALS AND LABOR SHALL BE IN ACCORDANCE WITH THE ABOVE CODE AND ALL OTHER APPLICABLE LOCAL CODES AT THE TIME OF MANUFACTURE.  
 WRITTEN DIMENSIONS SHALL TAKE PRECEDENCE OVER SCALED DIMENSIONS.  
 THE FOUNDATION PLAN IS A SEPARATE SET OF PLANS FOR APPROVAL BY LOCAL MUNICIPALITIES.  
 EXTERIOR DIMENSIONS CAN VARY BETWEEN LIMITS SHOWN AT 2' O.C. BUT MEMBER SPACING SHALL NOT EXCEED LIMITS AS INDICATED.  
 ALL THE FOLLOWING LUMBER SHALL BE PRESSURE TREATED IN ACCORDANCE WITH ANPA USE CATEGORY UC4B (GROUND CONTACT, HEAVY DUTY): SKIDS  
 ALL THE FOLLOWING LUMBER SHALL BE PRESSURE TREATED IN ACCORDANCE WITH ANPA USE CATEGORY UC3B (EXTERIOR ABOVE GROUND, UNCOATED OR  
 POOR WATER RUNOFF): FLOOR JOISTS, PLYWOOD FLOOR DECKING, AND EXTERIOR RATED WOOD STRUCTURAL PANEL SIDING.  
 ALL FASTENERS AND CONNECTORS IN CONTACT WITH PRESSURE TREATED WOOD SHALL BE HOT DIPPED GALVANIZED (G185) OR STAINLESS STEEL.  
 ALL WINDOWS WITHIN 24" OF DOORS, AND ALL GLASS IN DOORS SHALL BE SAFETY, TEMPERED, OR ACRYLIC PLASTIC SHEET.  
 FOR ROOFS WITH ASPHALT SHINGLES AND A SLOPE BETWEEN 2 TO 12 AND 4 TO 12 SHALL HAVE A DOUBLE UNDERLAYMENT APPLICATION AS REQUIRED IN  
 ACCORDANCE WITH SECTION 1507.2.8 OF THE 2012 I.B.C.  
 UNDERLAYMENT SHALL CONFORM WITH SECTION 1507.2.3 OF THE 2012 I.B.C.  
 ASPHALT SHINGLES SHALL CONFORM WITH SECTION 1507.2.5 OF THE 2012 I.B.C. ATTACHMENT OF ASPHALT SHINGLES SHALL CONFORM WITH 1507.2.7 OF THE  
 2012 F.B.C  
 FASTENERS FOR ASPHALT SHINGLES SHALL CONFORM TO SECTION 1507.2.6 OF THE 2012 I.B.C.  
 TIE-DOWNS SHALL MEET THE REQUIREMENTS OF ALL APPLICABLE CODES.  
 THESE PLANS HAVE NOT BEEN DESIGNED FOR HVHZ REQUIREMENTS AS SET FORTH IN THE 2012 I.B.C OR FOR USE AS A COMMERCIAL BUILDING.  
 THE CONTRACTOR SHALL BE RESPONSIBLE FOR VERIFYING ALL EXISTING CONDITIONS.  
 THE CONTRACTOR SHALL BE RESPONSIBLE FOR DELIVERY AND PLACEMENT OF LAWN STORAGE UNIT TO INSURE THE INTEGRITY OF THE BUILDING AND ITS  
 COMPONENT PARTS.  
 NO FIELD REVISIONS TO ANY STRUCTURAL COMPONENTS OR DEVIATIONS FROM THESE DRAWINGS SHALL BE MADE.  
 THE OWNER AND THE CONTRACTOR SHALL HOLD HARMLESS THE ENGINEER FROM AND AGAINST ALL LIABILITY CLAIMS, DAMAGES, LOSSES AND EXPENSES  
 INCLUDING LEGAL FEES ARISING OUT OF OR RESULTING FROM ERRORS OR OMISSIONS IN THE PERFORMANCE OF THE WORK BY THE CONTRACTOR.  
 SECTIONS AND DETAILS ON THE DRAWINGS ARE INTENDED TO BE TYPICAL AND SHALL APPLY AT ALL SIMILAR LOCATIONS, UNLESS OTHER SECTIONS AND  
 DETAILS ARE SPECIFICALLY REFERENCED.  
 REFER TO SUPPLIED FASTENING SCHEDULE FOR FASTENING BASED ON CONNECTION AND LOCATION OF MEMBERS AS PER 2012 INTERNATIONAL BUILDING  
 CODE TABLE 2304.9.1 UNLESS NOTED OTHERWISE.  
 BUILDINGS HAVE BEEN DESIGNED FOR LP SMARTSIDE PRECISION PANEL SIDING, LP SMARTSIDE PRECISION LAP SIDING SHALL NOT BE USED.  
 FASTENERS IN LP SMARTSIDE PRECISION PANEL SIDING MUST NOT BE INSTALLED IN PANEL SIDING GROOVES IN THE FIELD OF THE PANEL SIDING OR WHEN THE  
 PANEL SIDING GROOVES OCCUR AT CUT EDGES OF THE PANEL SIDING.  
 REFER TO THE ICC-ES EVALUATION REPORT ESR-1301 FOR ADDITIONAL DATA AND SPECIFICATIONS OF LP SMARTSIDE PRECISION PANEL SIDING.  
 MAX OPENINGS WIDTHS MUST COMPLY WITH DESIGN RATIOS AS PER ANSI/AF&PA SDPW5-2008. BUILDINGS HAVE BEEN DESIGNED TO HAVE ONLY OPENINGS  
 WITH MAX WIDTHS IN ENDWALL EQUAL TO THOSE IN THE ENDWALL SHEAR WALL CHART.  
 AS PER SECTION 553.17(10)(h), INTERNATIONAL STATUTES, STORAGE SHEDS THAT ARE NOT DESIGNED FOR HUMAN HABITATION AND THAT HAVE A FLOOR AREA  
 OF 720 SQUARE FEET OR LESS ARE NOT REQUIRED TO COMPLY WITH THE MANDATORY WIND-BORNE-DEBRIS-IMPACT STANDARDS OF THE INTERNATIONAL  
 BUILDING CODE. IN ADDITION, SUCH BUILDINGS THAT ARE 400 SQUARE FEET OR LESS AND THAT ARE INTENDED FOR USE IN CONJUNCTION WITH  
 ONE-AND-TWO-FAMILY RESIDENCES ARE NOT SUBJECT TO THE DOOR HEIGHT AND WIDTH REQUIREMENTS OF THE INTERNATIONAL BUILDING CODE.  
 BUILDINGS HAVE BEEN DESIGNED TO HAVE ANCHORS DIRECTLY ATTACHED TO ALL FOUR CORNERS OF THE BUILDING TO RESIST TENSION FORCES FROM  
 LATERAL WIND LOADS. THIS DESIGN CONSIDERATION MUST BE MADE BY INSTALLER WHEN ATTACHING ANCHORING SYSTEM TO BUILDING.  
 UNLESS NOTED OTHERWISE, ATTACH ALL MANUFACTURED PRODUCTS IN ACCORDANCE WITH MANUFACTURERS SPECIFICATIONS.

**SITE INSTALLED ITEMS**

NOTE THAT THIS LIST DOES NOT NECESSARILY LIMIT THE ITEMS OF WORK AND MATERIALS THAT MAY BE REQUIRED FOR A COMPLETE INSTALLATION. ALL SITE RELATED ITEMS ARE SUBJECT TO LOCAL JURISDICTIONAL APPROVAL.

- 1. THE COMPLETE FOUNDATION SUPPORT AND TIE-DOWN SYSTEM.
- 2. RAMPS, STAIRS, AND GENERAL ACCESS TO THE BUILDING IF NECESSARY.
- 3. GUTTERS AND DOWNSPOUTS ON ALL BUILDINGS WITH EAVES OF LESS THAN 6 INCHES HORIZONTAL PROJECTION EXCEPT FOR GABLE END RAKES.

**OCCUPANCY NOTE:**

THIS BUILDING IS NOT DESIGNED FOR HUMAN HABITATION AND DOES NOT HAVE RUNNING WATER OR SANITATION SERVICES. THIS BUILDING IS DESIGNED AS AN ACCESSORY LAWN STORAGE SHED TO STORE LAWN EQUIPMENT SUCH AS WHEEL BARROWS, GARDENING SUPPLIES, FLOWER POTS, AND CARDBOARD BOXES WITH VARIOUS SMALL ITEMS.

**AREA FOR APPROVAL STAMPS**



REV	BY	DATE	DESCRIPTION

THESE PLANS WERE DESIGNED IN ACCORDANCE WITH THE 2012 INTERNATIONAL BUILDING CODE, BUILDING CODE, WIND SPEED CATEGORY II, THIRD SECOND GUST OF 160 MPH.

**THOMAS A. DIXON, P.E.**

AL# 30637 MS# 19034 KS# 21198	DIXON ENGINEERING, INC.
SC# 27542 NC# 035485 GA# 034371	STRUCTURAL ENGINEERING AND INSPECTION - COA 8145
WV# 071436 TX# 104353 MD# 40905	10410 MAIN STREET
PA# 079009 VA# 045543	THONOTOSASSA, FL 33542
TN# 112761 FL# 34222	VOICE: 813-982-9885 FAX: 813-982-2306

**COOK PORTABLE WAREHOUSES**

GARDEN SHED  
 100 DOUGLAS STREET  
 VALDOSTA, GA 31601  
 PHONE: 1-224-241-8805

**NOTES**

DATE:	03/21/12
DRAWN BY:	JDA/DGF
CHECKED BY:	TAD
SCALE:	AS NOTED
N.O. NO:	495-064

SHEET  
**C-3**  
 3 OF 18

This drawing is the property of Dixon Engineering, Inc. Unless otherwise provided for by contract, or other written means, the contents of this drawing are confidential and shall not be transmitted to any other party except as agreed by Dixon Engineering, Inc. Copyright.

This drawing is the property of Dixon Engineering, Inc. Unless otherwise provided for by contract, or other written means, the contents of this drawing are confidential and shall not be transmitted to any other party except as agreed by Dixon Engineering, Inc. Copyright.

### FASTENING SCHEDULE

CONNECTION	FASTENING <sup>a, k</sup>	LOCATION
1. JOIST TO SILL OR GIRDER	3 - 8d COMMON (2 1/2" x 0.131") 3 - 3" x 0.131" NAILS 3 - 3" 14 GAGE STAPLES	TOENAIL
2. BRIDGING TO JOIST	2 - 8d COMMON (2 1/2" x 0.131") 2 - 3" x 0.131" NAILS 2 - 3" 14 GAGE STAPLES	TOENAIL EACH END
3. SOLE PLATE TO JOIST OR BLOCKING	16d (3 1/2" x 0.135") AT 16" O.C. 3" x 0.131" NAILS AT 8" O.C. 3" 14 GAGE STAPLES AT 12" O.C.	TYPICAL FACE NAIL
4. SOLE PLATE TO JOIST OR BLOCKING AT BRACED WALL PANEL	3 - 16d (3 1/2" x 0.135") AT 16" O.C. 4 - 3" x 0.131" NAILS AT 8" O.C. 4 - 3" 14 GAGE STAPLES AT 12" O.C.	BRACED WALL PANELS
5. TOP PLATE TO STUD	2 - 16d (3 1/2" x 0.162") 3 - 3" x 0.131" NAILS 3 - 3" 14 GAGE STAPLES	END NAIL
6. STUD TO SOLE PLATE	4 - 8d COMMON (2 1/2" x 0.131") 4 - 3" x 0.131" NAILS 3 - 3" 14 GAGE STAPLES  2 - 16d COMMON (3 1/2" x 0.162") 3 - 3" x 0.131" NAILS 3 - 3" 14 GAGE STAPLES	TOENAIL  END NAIL
7. DOUBLE STUDS	16d (3 1/2" x 0.135") AT 24" O.C. 3" x 0.131" NAILS AT 8" O.C. 3" 14 GAGE STAPLES AT 12" O.C.	FACE NAIL
8. DOUBLE TO PLATES	16d (3 1/2" x 0.135") AT 16" O.C. 3" x 0.131" NAILS AT 12" O.C. 3" 14 GAGE STAPLES AT 12" O.C.  8 - 16d COMMON (3 1/2" x 0.162") 12 - 3" x 0.131" NAILS 12 - 3" 14 GAGE STAPLES	TYPICAL FACE NAIL  LAP SPLICE
9. BLOCKING BETWEEN JOISTS OR RAFTERS TO TOP PLATE	3 - 8d COMMON (2 1/2" x 0.131") 3 - 3" x 0.131" NAILS 3 - 3" 14 GAGE STAPLES	TOENAIL
10. RIM JOIST TO TOP PLATE	8d (2 1/2" x 0.131") AT 6" O.C. 3" x 0.131" NAILS AT 6" O.C. 3" 14 GAGE STAPLES AT 6" O.C.	TOENAIL
11. TOP PLATES, LAPS AND INTERSECTIONS	2 - 16d COMMON (3 1/2" x 0.162") 3 - 3" x 0.131" NAILS 3 - 3" 14 GAGE STAPLES	FACE NAIL
12. CONTINUOUS HEADER (2) PIECES	16d COMMON (3 1/2" x 0.162")	16" O.C. ALONG EDGE

(CONTINUED)

### AREA FOR APPROVAL STAMPS



REV	BY	DATE	DESCRIPTION

THESE PLANS WERE DESIGNED IN ACCORDANCE WITH THE 2012 INTERNATIONAL BUILDING CODE, BUILDING SPEED WIND RESISTANCE SECOND GUST OF 160 MPH.

## THOMAS A. DIXON, P.E.

AL# 30637 MS# 19034 KS# 21198	DIXON ENGINEERING, INC.
SC# 27592 NC# 035985 GA# 034371	STRUCTURAL ENGINEERING AND INSPECTION - COA 8195
WV# 071936 TX# 104353 MD# 40905	10410 MAIN STREET
PA# 079009 VA# 045593	THONOTOSASSA, FL 33542
TN# 112761 FL# 34222	VOICE: 813-982-9885 FAX: 813-982-2306

### COOK PORTABLE WAREHOUSES

GARDEN SHED  
100 DOUGLAS STREET  
VALDOSTA, GA 31601  
PHONE: 1-229-241-8805

## FASTENING SCHEDULE

DATE: 03/21/12  
DRAWN BY: JDA/DGF  
CHECKED BY: TAD  
SCALE: AS NOTED  
W.O. NO: 495-064

SHEET

# C-4

4 OF 18

This drawing is the property of Dixon Engineering, Inc. Unless otherwise provided for by contract, or other written means, the contents of this drawing are confidential and shall not be transmitted to any other party except as agreed by Dixon Engineering, Inc. Copyright.

**FASTENING SCHEDULE**

CONNECTION	FASTENING <sup>a, k</sup>	LOCATION
13. CEILING JOISTS TO PLATE	3 - 8d COMMON (2 1/2" x 0.131") 5 - 3" x 0.131" NAILS 5 - 3" 14 GAGE STAPLES	TOENAIL
14. CONTINUOUS HEADER TO STUD	4 - 8d COMMON (2 1/2" x 0.131")	TOENAIL
15. RAFTER TO PLATE	3 - 8d COMMON (2 1/2" x 0.131") 3 - 3" x 0.131" NAILS 3 - 3" 14 GAGE STAPLES	TOENAIL
16. 1" DIAGONAL BRACE TO EACH STUD AND PLATE	2 - 8d COMMON (2 1/2" x 0.131") 2 - 3" x 0.131" NAILS 3 - 3" 14 GAGE STAPLES	FACE NAIL
17. BUILT-UP CORNER STUDS	16d (3 1/2" x 0.135") 3" x 0.131" NAILS 3" 14 GAGE STAPLES	24" O.C. 16" O.C. 16" O.C.
18A. BUILT-UP GIRDER AND BEAMS	20d COMMON (4" x 0.142" 32") O.C. 3" x 0.131" NAIL AT 24" O.C. 3" 14 GAGE STAPLE AT 24" O.C.  2 - 20d COMMON (4" x 0.142") 3 - 3" x 0.131" NAIL 3 - 3" 14 GAGE STAPLE	FACE NAIL AT TOP AND BOTTOM STAGGERED ON OPPOSITE SIDES  FACE NAIL AT ENDS AND AT EACH SPLICE
19. COLLAR TIE TO RAFTER	3 - 10d COMMON (3" x 0.148") 4 - 3" x 0.131" NAILS 4 - 3" 14 GAGE STAPLES	FACE NAIL
20. ROOF RAFTER TO 2-BY RIDGE BEAM	2 - 16d COMMON (3 1/2" x 0.162") 3 - 3" x 0.131" NAILS 3 - 3" 14 GAGE STAPLES	TOENAIL OR FACE NAIL
21. JOIST TO BAND JOIST	3 - 16d COMMON (3 1/2" x 0.162") 4 - 3" x 0.131" NAILS 4 - 3" 14 GAGE STAPLES	FACE NAIL

(CONTINUED)

**AREA FOR APPROVAL STAMPS**

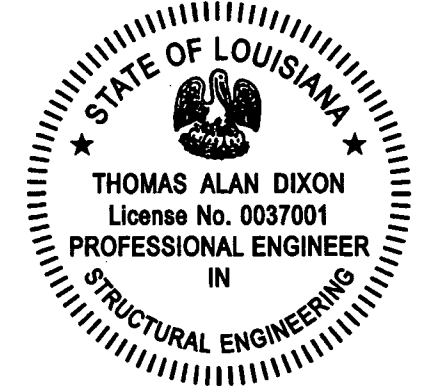

REV	BY	DATE	DESCRIPTION

THESE PLANS WERE DESIGNED IN ACCORDANCE WITH THE 2012 INTERNATIONAL BUILDING CODE, BUILDING WIND SPEED CATEGORY III SECOND GUST OF 160 MPH.

**THOMAS A. DIXON, P.E.**  
 AL# 30637 MS# 19034 KS# 21198  
 SC# 27542 NC# 035405 GA# 034371  
 WV# 071936 TX# 104353 MD# 40905  
 PA# 079009 VA# 045593  
 TN# 112761 FL# 34222

DIXON ENGINEERING, INC.  
 STRUCTURAL ENGINEERING AND INSPECTION - COA 0145  
 10410 MAIN STREET  
 THONOTOSASSA, FL 33542  
 VOICE: 813-982-9885 FAX: 813-982-2306

**COOK PORTABLE WAREHOUSES**  
 GARDEN SHED  
 100 DOUGLAS STREET  
 VALDOSTA, GA 31601  
 PHONE: 1-229-241-8805

**FASTENING SCHEDULE (CONT.)**

THOMAS A. DIXON  
 LICENSED PROFESSIONAL ENGINEER  
 19034  
 STATE OF MISSISSIPPI

03/21/12

DATE: 03/21/12  
 DRAWN BY: JDA/DGF  
 CHECKED BY: TAD  
 SCALE: AS NOTED  
 W.O. NO: 495-064

SHEET  
**C-5**  
 5 OF 18

This drawing is the property of Dixon Engineering, Inc. Unless otherwise provided for by contract, or other written means, the contents of this drawing are confidential and shall not be transmitted to any other party except as agreed by Dixon Engineering, Inc. Copyright.

<b>FASTENING SCHEDULE</b>		
CONNECTION	FASTENING <sup>a, k</sup>	LOCATION
22. WOOD STRUCTURAL PANELS AND PARTICLEBOARD <sup>b</sup> SUBFLOOR, ROOF AND WALL SHEATHING (TO FRAMING)  SINGLE FLOOR (COMBINATION SUBFLOOR-UNDERLAYMENT TO FRAMING)	1/2" AND LESS    6d <sup>c, j</sup> 2 3/8" x 0.113" NAIL <sup>l</sup> 1 3/4" 16 GAGE <sup>m</sup>	6 INCH O.C. EDGES AND INTERMEDIATE, 4" O.C. AT COMPONENT AND CLADDING EDGE STRIP # ZONE 3 [REFER TO FIGURE 30.5-1 OF ASCE 7]
	15/32" TO 19/32"    8d COMMON (ROOFS IN I10-140 V <sub>asd</sub> MPH EXP "B")	
	19/32" TO 3/4"    8d <sup>d</sup> OR 6d <sup>e</sup> 2 3/8" x 0.113" NAIL <sup>n</sup> 2" 16 GAGE <sup>n</sup>	
	7/8" TO 1"    8d <sup>c</sup>	
	1 1/8" TO 1 1/4"    10d <sup>d</sup> OR 8d <sup>e</sup>	
	3/4" AND LESS    6d <sup>e</sup>	
	7/8" TO 1"    8d <sup>e</sup>	
23. PANEL SIDING (TO FRAMING)	1/2" OR LESS    6d <sup>f</sup> 5/8"    8d <sup>f</sup>	
	24. FIBERBOARD SHEATHING <sup>g</sup>	
1/2"    NO. 11 GAGE ROOFING NAIL <sup>h</sup> 6d COMMON NAIL (2" x 0.113") NO 16 GAGE STAPLE <sup>i</sup>		
25/32"    NO. 11 GAGE ROOFING NAIL <sup>h</sup> 8d COMMON NAIL (2 1/2" x 0.131") NO 16 GAGE STAPLE <sup>i</sup>		

COMMON OR BOX NAILS ARE PERMITTED TO BE USED EXCEPT WHERE OTHERWISE STATED.  
 NAILS SPACED AT 6" O.C. AT EDGES, 12" AT INTERMEDIATE SUPPORTS EXCEPT 6" AT SUPPORTS WHERE SPANS ARE 48" OR MORE. FOR NAILING OF WOOD STRUCTURAL PANEL AND PARTICLEBOARD DIAPHRAGMS AND SHEAR WALLS, REFER TO SECTION 2305 I.B.C.. NAILS FOR WALL SHEATHING ARE PERMITTED TO BE COMMON, BOX OR CASING.  
 COMMON OR DEFORMED SHANK (6d - 2" x 0.113"; 8d - 2 1/2" x 0.131"; 10d 3" x 0.148").  
 COMMON (6d - 2" x 0.113"; 8d - 2 1/2" x 0.131"; 10d 3" x 0.148").  
 DEFORMED SHANK (6d - 2" x 0.113"; 8d - 2 1/2" x 0.131"; 10d 3" x 0.148").  
 CORROSION-RESISTANT SIDING (6d - 1 7/8" x 0.106"; 8d 2 3/8" x 0.128") OR CASING (6d 2" x 0.099"; 8d 2 1/2" x 0.113") NAIL.  
 FASTENERS SPACED 3" O.C. AT EXTERIOR EDGES AND 6" O.C. AT INTERMEDIATE SUPPORTS, WHEN USED AS STRUCTURAL SHEATHING. SPACING SHALL BE 6" O.C. ON THE EDGES AND 12" O.C. AT INTERMEDIATE SUPPORTS FOR NONSTRUCTURAL APPLICATIONS.  
 CORROSION-RESISTANT ROOFING NAILS WITH 7/16" DIAMETER HEAD AND 1 1/2" LENGTH FOR 1/2" SHEATHING AND 1 3/4" LENGTH FOR 25/32" SHEATHING.  
 CORROSION-RESISTANT STAPLES WITH NOMINAL 7/16" CROWN OR 1" CROWN AND 1 1/4" LENGTH FOR 1/2" SHEATHING AND 1 1/2" LENGTH FOR 25/32" SHEATHING. PANEL SUPPORTS AT 16" (20" IF STRENGTH AXIS IS THE LONG DIRECTION OF THE PANEL, UNLESS OTHERWISE MARKED).  
 FOR ROOF SHEATHING APPLICATIONS, 8d NAILS (2 1/2" x 0.113") ARE THE MINIMUM REQUIRED FOR WOOD STRUCTURAL PANELS.  
 STAPLES SHALL HAVE A MINIMUM CROWN WIDTH OF 7/16".  
 FOR ROOF SHEATHING APPLICATIONS, FASTENERS SPACED 4" O.C. AT EDGES, 8" O.C. AT INTERMEDIATE SUPPORTS.  
 FASTENERS SPACED 4" O.C. AT EDGES, 8" O.C. AT INTERMEDIATE SUPPORTS FOR SUBFLOOR AND WALL SHEATHING AND 3" O.C. AT EDGES, 6" AT INTERMEDIATE SUPPORTS FOR ROOF SHEATHING.  
 FASTENERS SPACED 4" O.C. AT EDGES, 8" AT INTERMEDIATE SUPPORTS.

**AREA FOR APPROVAL STAMPS**

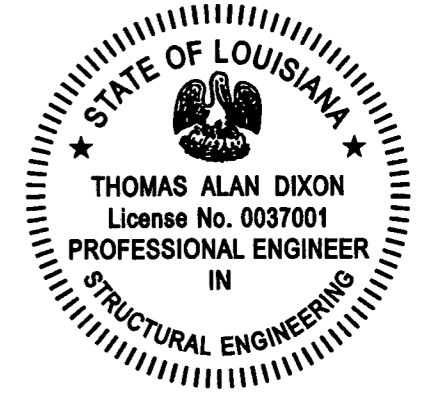

REV	BY	DATE	DESCRIPTION		

THESE PLANS WERE DESIGNED IN ACCORDANCE WITH THE 2012 INTERNATIONAL BUILDING CODE, BUILDING FOR WIND SPEEDS TO THE SECOND GUST OF 160 MPH.

<b>THOMAS A. DIXON, P.E.</b>	
AL# 30637 MS# 19034 KS# 21198 SC# 27592 NC# 035485 GA# 034371 MV# 071936 TX# 104353 MD# 40905 PA# 079009 VA# 045543 TN# 112761 FL# 34222	DIXON ENGINEERING, INC. STRUCTURAL ENGINEERING AND INSPECTION - COA 8145 10410 MAIN STREET THONOTOSASSA, FL 33542 VOICE: 813-982-9805 FAX: 813-982-2306

<b>COOK PORTABLE WAREHOUSES</b> GARDEN SHED 100 DOUGLAS STREET VALDOSTA, GA 31601 PHONE: 1-229-241-8805  <b>FASTENING SCHEDULE (CONT.)</b>
--

--

DATE:	03/21/12
DRAWN BY:	JDA/DGF
CHECKED BY:	TAD
SCALE:	AS NOTED
W.O. NO.:	495-064

SHEET <b>C-6</b> 6 OF 18
--------------------------------

This drawing is the property of Dixon Engineering, Inc. Unless otherwise provided for by contract, or other written means, the contents of this drawing are confidential and shall not be transmitted to any other party except as agreed by Dixon Engineering, Inc. Copyright.

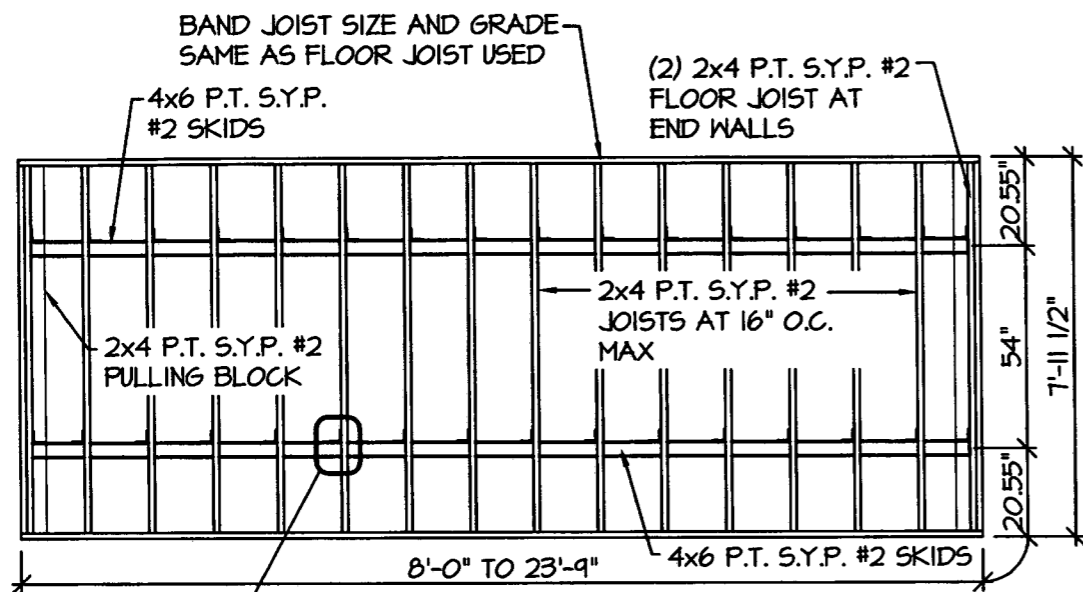

3  
A-9

1  
A-1  
**FLOOR FRAMING PLAN**  
SCALE: 1/4" = 1'-0"

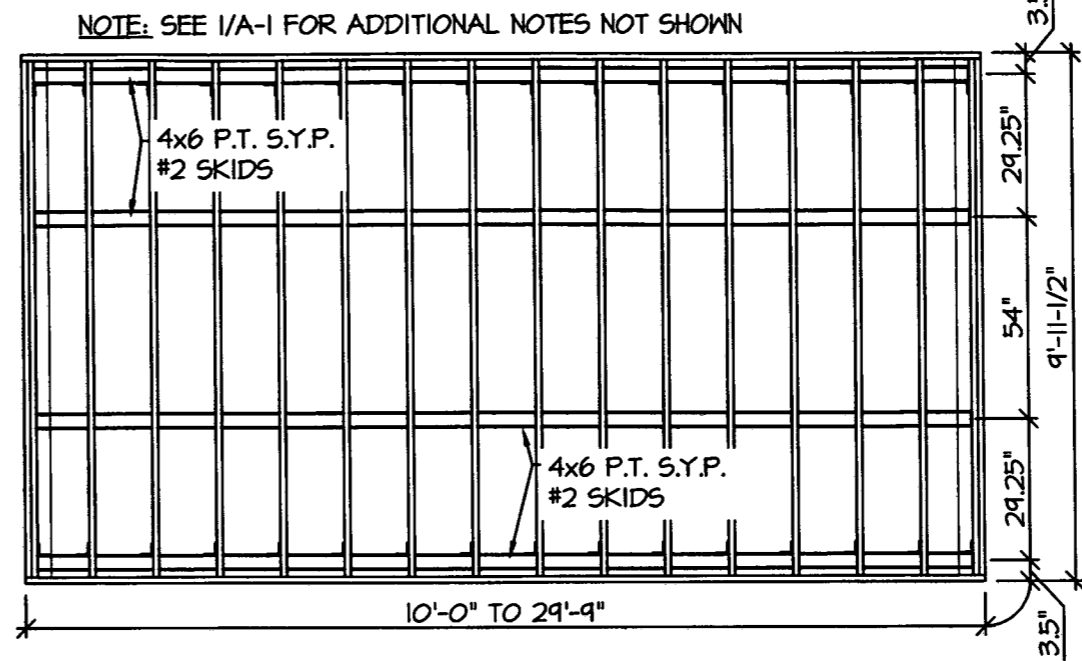

2  
A-1

2  
A-1  
**FLOOR FRAMING PLAN**  
SCALE: 1/4" = 1'-0"

EXAMPLE DRAWINGS ARE OF A 20' LENGTH UNIT

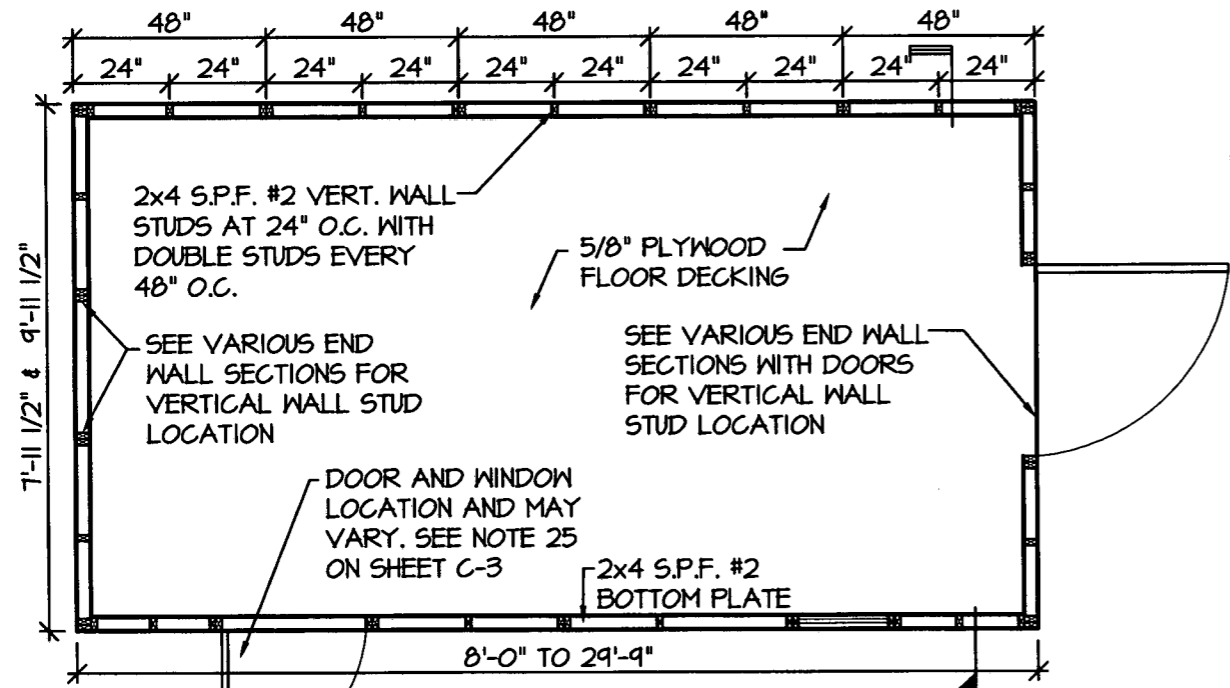

3  
A-1

3  
A-1  
**FLOOR DECK PLAN**  
SCALE: 1/4" = 1'-0"

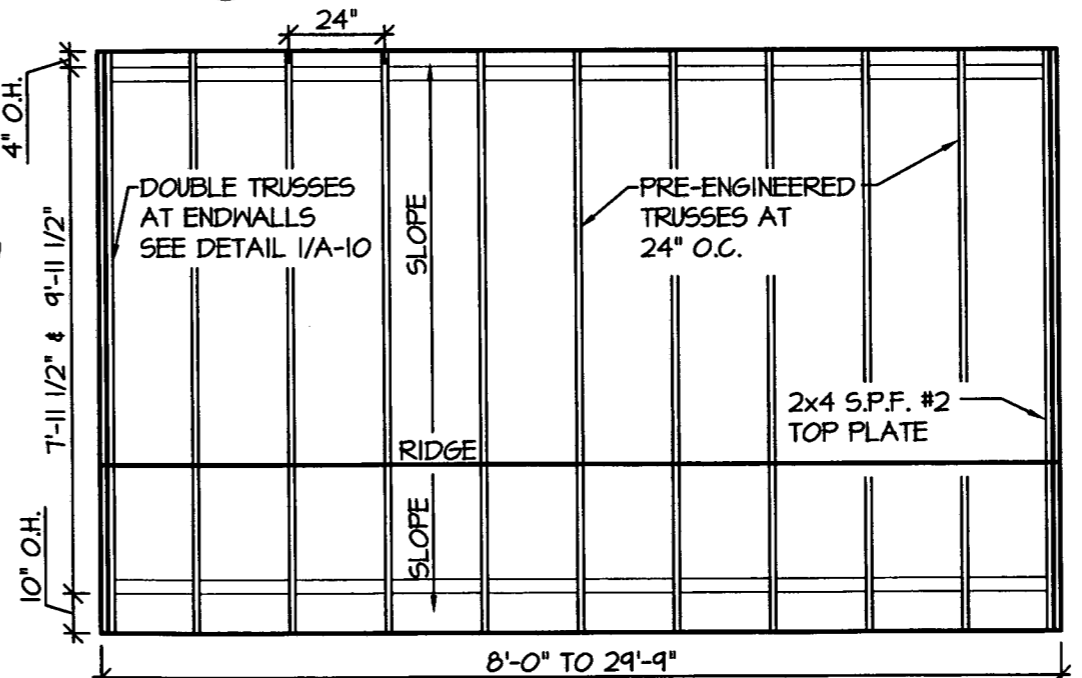

4  
A-1

4  
A-1  
**ROOF FRAMING PLAN**  
SCALE: 1/4" = 1'-0"

**AREA FOR APPROVAL STAMPS**



REV	BY	DATE	DESCRIPTION

THESE PLANS WERE DESIGNED IN ACCORDANCE WITH THE 2012 INTERNATIONAL BUILDING CODE, BUILDING FOR WINDS TO THE SECOND GUST OF 160 MPH.

**THOMAS A. DIXON, P.E.**

AL# 30637 MS# 19034 KS# 21198  
SC# 27592 NC# 035485 GA# 034371  
NV# 071936 TX# 104353 MD# 40905  
PA# 079009 VA# 045543  
TN# 112761 FL# 34222

DIXON ENGINEERING, INC.  
STRUCTURAL ENGINEERING AND INSPECTION - COA 8195  
10410 MAIN STREET  
THONOTOSASSA, FL 33542  
VOICE: 813-982-9805 FAX: 813-982-2306

**COOK PORTABLE WAREHOUSES**  
GARDEN SHED  
100 DOUGLAS STREET  
VALDOSTA, GA 31601  
PHONE: 1-229-241-8805

**FLOOR DECK AND FRAMING PLANS**

DATE: 03/27/12  
DRAWN BY: JDA/DGF  
CHECKED BY: TAD  
SCALE: AS NOTED  
N.O. NO: 495-064

SHEET  
**A-1**  
7 OF 18

This drawing is the property of Dixon Engineering, Inc. Unless otherwise provided for by contract, or other written means, the contents of this drawing are confidential and shall not be transmitted to any other party except as agreed by Dixon Engineering, Inc. Copyright.

# SHEARWALL CHART

BUILDING WIDTH	OPENING WIDTHS IN ENDWALL	MAX LENGTH OF BUILDING			
		19/32" TI-11 <sup>1</sup>	19/32" PANEL <sup>1,3</sup> OUTSIDE WITH 7/16" OSB <sup>2</sup> ON INTERIOR OF WALL	19/32" LP SMARTPANEL <sup>3</sup>	19/32" LP SMART-PANEL <sup>4</sup>
7'-11 1/2"	NONE	23'-10"	23'-10"	23'-10"	23'-10"
	3'-0" MAX	23'-10"		23'-10"	23'-10"
	4'-0"	23'-10"		21'-11"	23'-10"
9'-11 1/2"	NONE	29'-10"	29'-10"	29'-10"	29'-10"
	3'-0" MAX	29'-10"		29'-10"	29'-10"
	4'-0"	29'-10"		29'-10"	29'-10"
	6'-0"	29'-10"		21'-11"	27'-10"
	7'-0"	25'-9"		16'-4"	20'-10"

**1** SHEARWALL TABLE  
**A-2** SCALE: N.T.S.

**NOTES:**

1. 19/32" TI-11 SHALL BE FASTENED USING 8d COMMON OR DEFORMED NAILS AT 6" O.C. IN FIELD AND 3" O.C. ALONG ALL PANEL EDGES.
2. 7/16" OSB SHALL BE FASTENED USING 8d COMMON OR DEFORMED NAILS AT 6" O.C. IN FIELD AND 4" O.C. ALONG ALL PANEL EDGES.
3. 19/32" LP SMARTPANEL SHALL BE FASTENED USING 8d COMMON OR DEFORMED NAILS AT 6" O.C. IN FIELD AND 3" O.C. ALONG ALL PANEL EDGES.
4. 19/32" LP SMARTPANEL SHALL BE FASTENED USING 8d COMMON OR DEFORMED NAILS AT 6" O.C. IN FIELD AND 2" O.C. ALONG ALL PANEL EDGES.
5. WINDOWS AND DOORS MAY BE LOCATED IN EITHER THE SIDE WALL OR ENDWALL. DOORS ARE PERMITTED TO BE IN BOTH ENDWALLS OR ENDWALL AND SIDE WALL IF REQUESTED BY CUSTOMER. LIMITATIONS ON THE TOTAL OPENING DIMENSIONS IN SIDEWALLS SHALL BE BASED ON A MAXIMUM TOTAL OPENING WIDTHS OF (2/3) OF TOTAL LENGTH OF BUILDING.

**AREA FOR APPROVAL STAMPS**

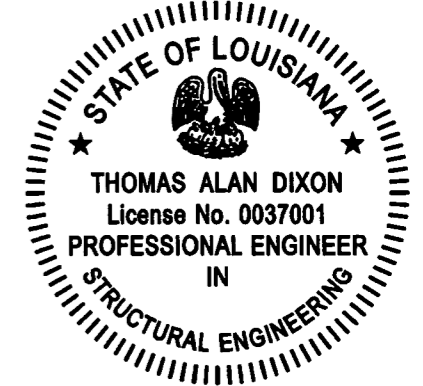

REV	BY	DATE	DESCRIPTION

THESE PLANS WERE DESIGNED IN ACCORDANCE WITH THE 2012 INTERNATIONAL BUILDING CODE, BUILDING CATEGORY II, WIND SPEED SECOND GUST OF 160 MPH.													
<p><b>THOMAS A. DIXON, P.E.</b></p> <p>AL# 30637 MS# 19034 KS# 21198          SC# 27592 NC# 035485 GA# 034371          NV# 071936 TX# 104353 MD# 40905          PA# 079009 VA# 045543          TN# 112761 FL# 34222</p>	<p><b>COOK PORTABLE WAREHOUSES</b></p> <p>GARDEN SHED          100 DOUGLAS STREET          VALDOSTA, GA 31601          PHONE: 1-229-241-8805</p>		<table border="1" style="width: 100%; border-collapse: collapse;"> <tr><td>DATE:</td><td>03/21/12</td></tr> <tr><td>DRAWN BY:</td><td>JDA/DGF</td></tr> <tr><td>CHECKED BY:</td><td>TAD</td></tr> <tr><td>SCALE:</td><td>AS NOTED</td></tr> <tr><td>W.O. NO.:</td><td>495-064</td></tr> </table>	DATE:	03/21/12	DRAWN BY:	JDA/DGF	CHECKED BY:	TAD	SCALE:	AS NOTED	W.O. NO.:	495-064
DATE:	03/21/12												
DRAWN BY:	JDA/DGF												
CHECKED BY:	TAD												
SCALE:	AS NOTED												
W.O. NO.:	495-064												
<p><b>SHEARWALL TABLE</b></p>			<p>SHEET  <b>A-2</b>          B OF 18</p>										



This drawing is the property of Dixon Engineering, Inc. Unless otherwise provided for by contract, or other written means, the contents of this drawing are confidential and shall not be transmitted to any other party except as agreed by Dixon Engineering, Inc. Copyright.

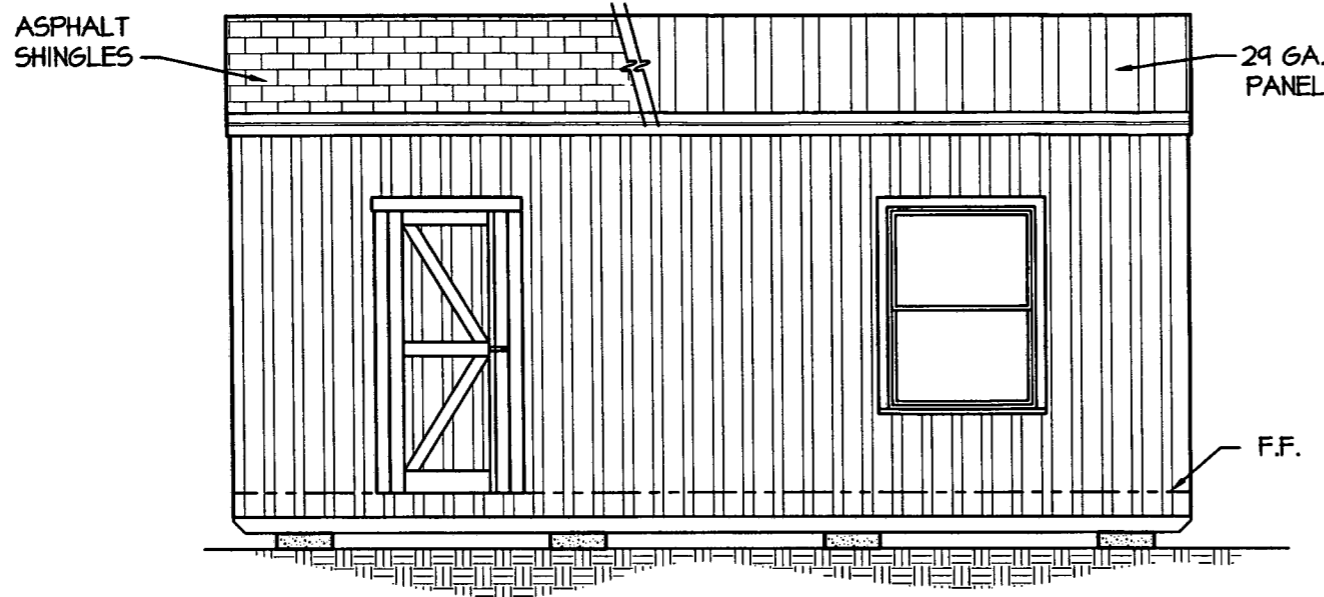

1 SIDE ELEVATION  
A-3 SCALE: 1/4" = 1'-0"

EXAMPLE DRAWING IS OF A 20' LENGTH UNIT  
NOTE:  
1. FOR ALL ITEMS NOT SHOWN SEE SHEET A-4

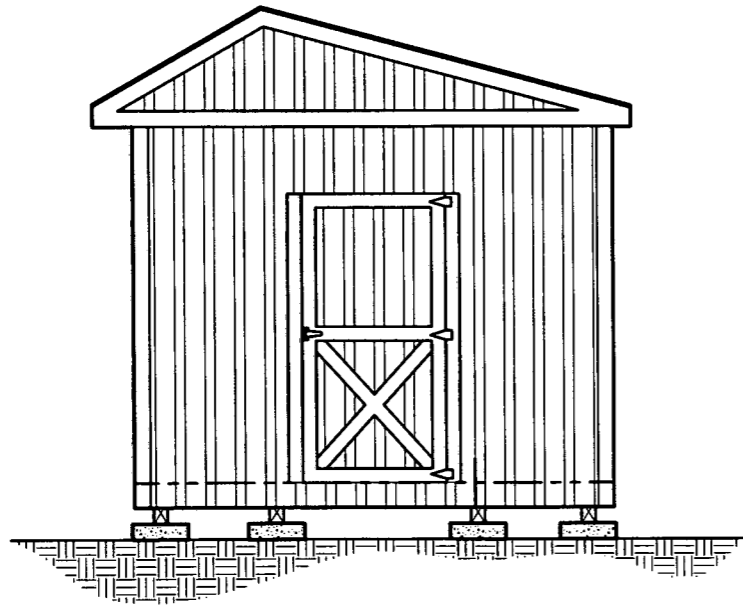

EXAMPLE DRAWING IS OF A 10'  
WIDE UNIT W/ 3'-0" DOOR

2 ENDWALL ELEVATION  
A-3 SCALE: 1/4" = 1'-0"

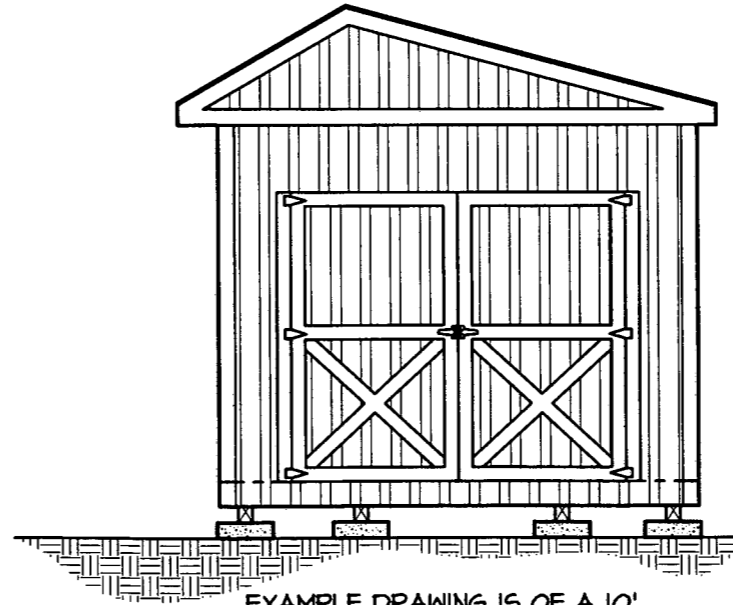

EXAMPLE DRAWING IS OF A 10'  
WIDE UNIT W/ 7'-0" DOOR

AREA FOR APPROVAL STAMPS

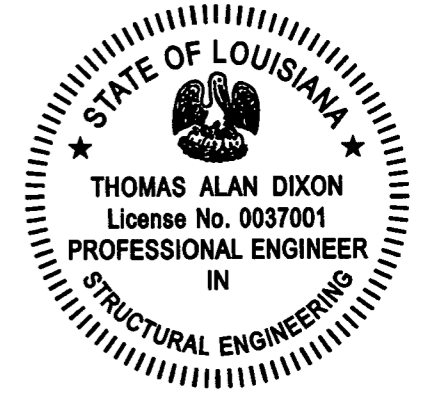

REV	BY	DATE	DESCRIPTION

THESE PLANS WERE DESIGNED IN ACCORDANCE WITH THE 2012 INTERNATIONAL BUILDING CODE, BUILDING LOADS AND WINDS, SECOND GUST OF 160 MPH.

**THOMAS A. DIXON, P.E.**  
 AL# 30637 MS# 19034 KS# 21198 DIXON ENGINEERING, INC.  
 SC# 27592 NC# 035485 GA# 034371 STRUCTURAL ENGINEERING AND INSPECTION - COA 8145  
 WV# 071936 TX# 104353 MD# 40905 10410 MAIN STREET  
 PA# 079009 VA# 045593 THONOTOSASSA, FL 33592  
 TN# 112761 FL# 34222 VOICE: 813-982-9885 FAX: 813-982-2306

**COOK PORTABLE WAREHOUSES**  
 GARDEN SHED  
 100 DOUGLAS STREET  
 VALDOSTA, GA 31601  
 PHONE: 1-229-241-8805  
**EXTERIOR ELEVATIONS**

DATE:	03/21/12
DRAWN BY:	JDADGF
CHECKED BY:	TAD
SCALE:	AS NOTED
W.O. NO.:	495-064

This drawing is the property of Dixon Engineering, Inc. Unless otherwise provided for by contract, or other written means, the contents of this drawing are confidential and shall not be transmitted to any other party except as agreed by Dixon Engineering, Inc. Copyright.

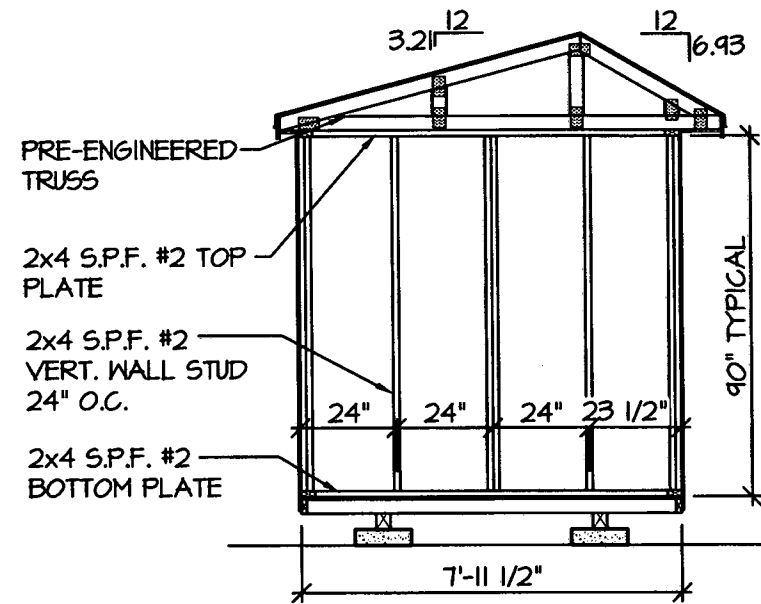

1  
A-4 **7'-11 1/2" SHED ENDWALL WITH NO OPENING FRAMING ELEVATION**  
SCALE: 1/4" = 1'-0"

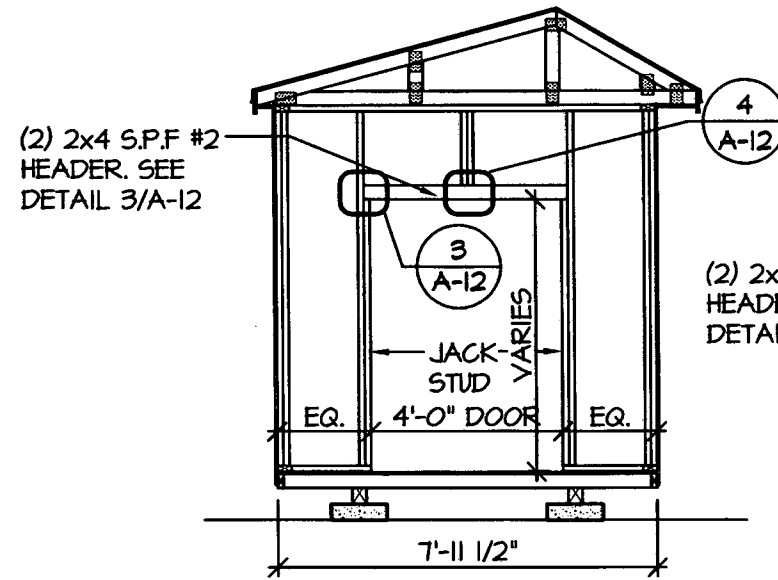

2  
A-4 **7'-11 1/2" SHED ENDWALL WITH 4' DOOR OPENING FRAMING ELEVATION**  
SCALE: 1/4" = 1'-0"

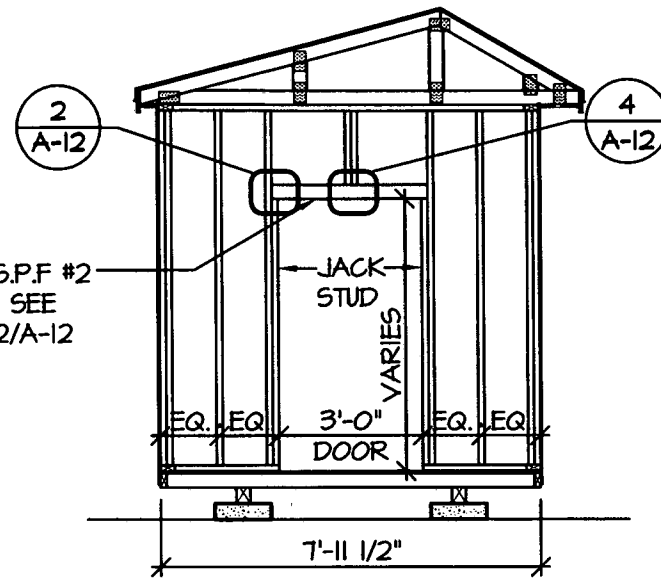

3  
A-4 **7'-11 1/2" SHED ENDWALL WITH 3' DOOR OPENING FRAMING ELEVATION**  
SCALE: 1/4" = 1'-0"

**NOTE:**  
1. FOR ALL ITEMS NOT SHOWN SEE SHEET A-4

**AREA FOR APPROVAL STAMPS**

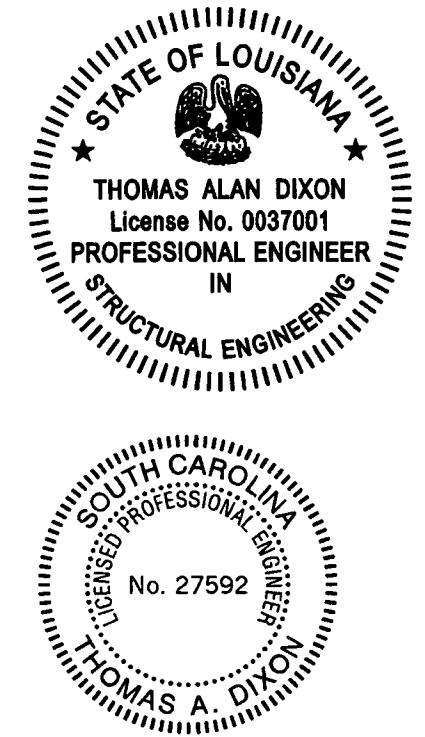

REV	BY	DATE	DESCRIPTION

THESE PLANS WERE DESIGNED IN ACCORDANCE WITH THE 2012 INTERNATIONAL BUILDING CODE, BUILDING WIND SPEED CATEGORY II, WIND SPEED OF 130 MPH, SECOND GUST OF 160 MPH.

**THOMAS A. DIXON, P.E.**  
AL# 30637 MS# 19034 KS# 21198  
SC# 27542 NC# 035485 GA# 034371  
WV# 071936 TX# 104353 MD# 40905  
PA# 079009 VA# 045543  
TN# 112761 FL# 34222  
DIXON ENGINEERING, INC.  
STRUCTURAL ENGINEERING AND INSPECTION - COA 8195  
10410 MAIN STREET  
THONOTOSASSA, FL 33542  
VOICE: 813-982-9885 FAX: 813-982-2306

**COOK PORTABLE WAREHOUSES**  
GARDEN SHED  
100 DOUGLAS STREET  
VALDOSTA, GA 31601  
PHONE: 1-229-241-8805  
**FRAMING ELEVATIONS**

DATE: 03/27/12  
DRAWN BY: JDA/DGF  
CHECKED BY: TAD  
SCALE: AS NOTED  
N.O. NO: 495-064

SHEET  
**A-4**  
10 OF 18

This drawing is the property of Dixon Engineering, Inc. Unless otherwise provided for by contract, or other written means, the contents of this drawing are confidential and shall not be transmitted to any other party except as agreed by Dixon Engineering, Inc. Copyright.

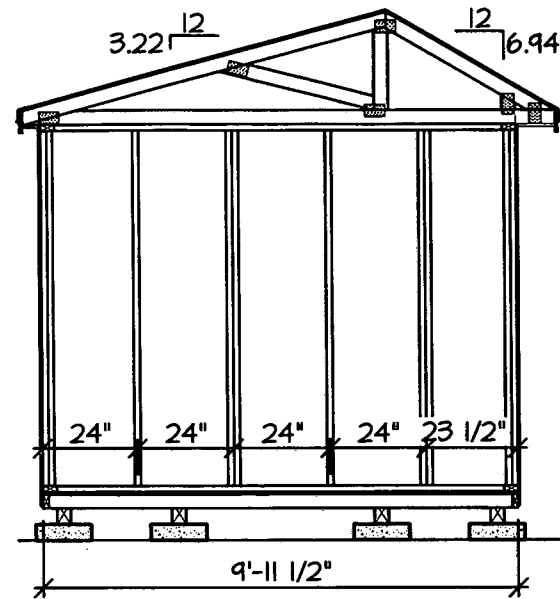

1  
A-5  
9'-11 1/2" SHED ENDWALL WITH NO OPENING  
**FRAMING ELEVATION**  
SCALE: 1/4" = 1'-0"

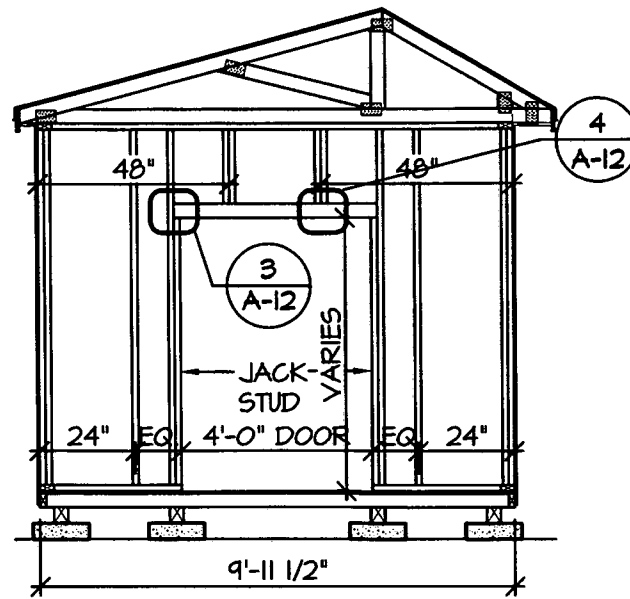

2  
A-5  
9'-11 1/2" SHED ENDWALL WITH 4' DOOR OPENING  
**FRAMING ELEVATION**  
SCALE: 1/4" = 1'-0"

NOTE:  
1. FOR ALL ITEMS NOT SHOWN SEE SHEET A-4

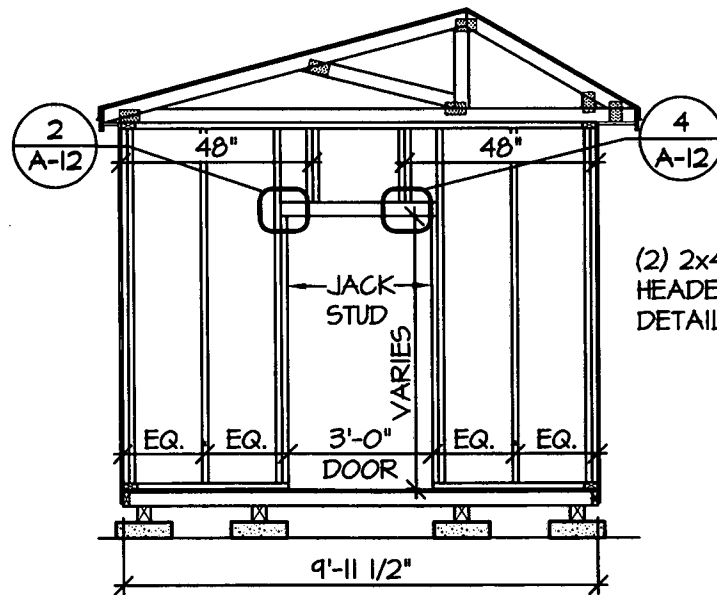

3  
A-5  
9'-11 1/2" SHED ENDWALL WITH 3' DOOR OPENING  
**FRAMING ELEVATION**  
SCALE: 1/4" = 1'-0"

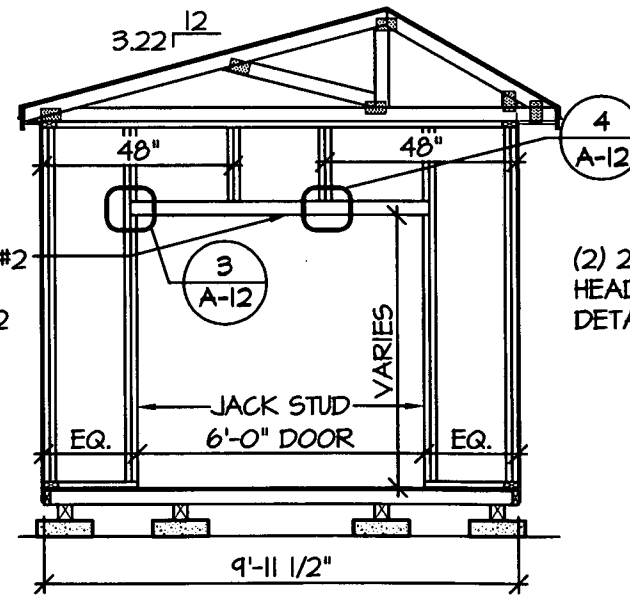

4  
A-5  
9'-11 1/2" SHED ENDWALL WITH 6' DOOR OPENING  
**FRAMING ELEVATION**  
SCALE: 1/4" = 1'-0"

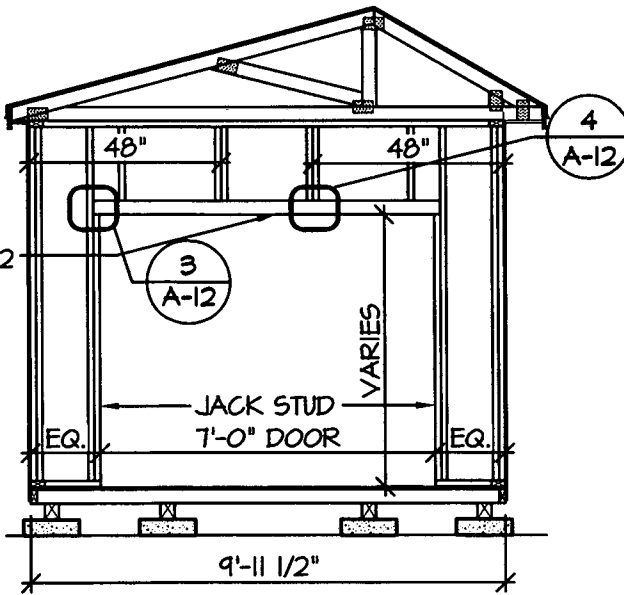

5  
A-5  
9'-11 1/2" SHED ENDWALL WITH 7' DOOR OPENING  
**FRAMING ELEVATION**  
SCALE: 1/4" = 1'-0"

AREA FOR APPROVAL STAMPS

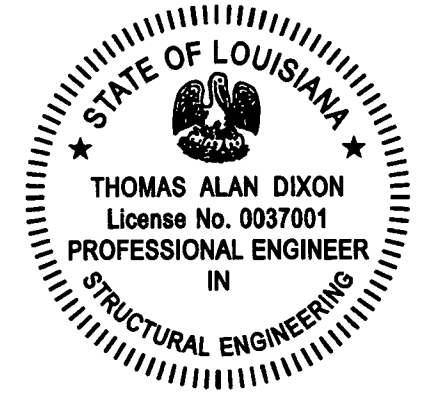

REV	BY	DATE	DESCRIPTION

THESE PLANS WERE DESIGNED IN ACCORDANCE WITH THE 2012 INTERNATIONAL BUILDING CODE, BUILDING FOR WINDSPEED CATEGORY II AND SECOND GUST OF 160 MPH.

**THOMAS A. DIXON, P.E.**  
 AL# 30637 MS# 19034 KS# 21198  
 SC# 27592 NC# 035985 GA# 034371  
 NV# 071936 TX# 104353 MD# 40905  
 PA# 079009 VA# 045543  
 TN# 112761 FL# 34222  
 DIXON ENGINEERING, INC.  
 STRUCTURAL ENGINEERING AND INSPECTION - COA 8195  
 10410 MAIN STREET  
 THONOTOSASSA, FL 33542  
 VOICE: 813-982-9885 FAX: 813-982-2306

**COOK PORTABLE WAREHOUSES**  
 GARDEN SHED  
 100 DOUGLAS STREET  
 VALDOSTA, GA 31601  
 PHONE: 1-229-241-8805  
**FRAMING ELEVATIONS**

DATE: 03/21/12  
 DRAWN BY: JDA/DGF  
 CHECKED BY: TAD  
 SCALE: AS NOTED  
 W.O. NO: 495-064

SHEET  
**A-5**  
 11 OF 18

This drawing is the property of Dixon Engineering, Inc. Unless otherwise provided for by contract, or other written means, the contents of this drawing are confidential and shall not be transmitted to any other party except as agreed by Dixon Engineering, Inc. Copyright.

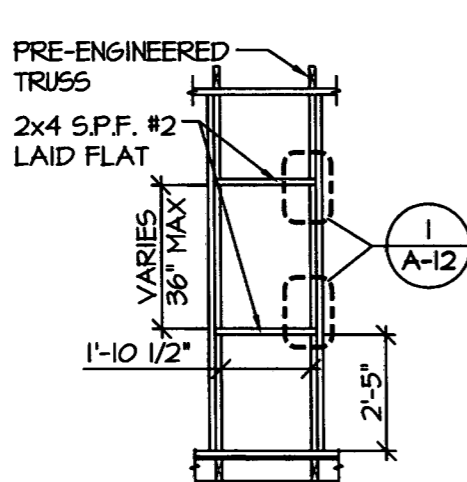

1  
A-6  
SIDEWALL OR ENDWALL  
2'-0" NOMINAL WINDOW HEADER AND SILL  
**FRAMING ELEVATION**  
SCALE: 1/4" = 1'-0"

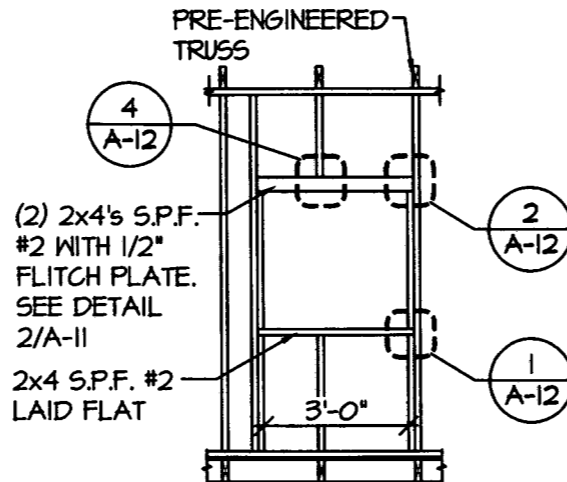

2  
A-6  
SIDEWALL  
3'-0" OPENING HEADER AND SILL  
**FRAMING ELEVATION**  
SCALE: 1/4" = 1'-0"

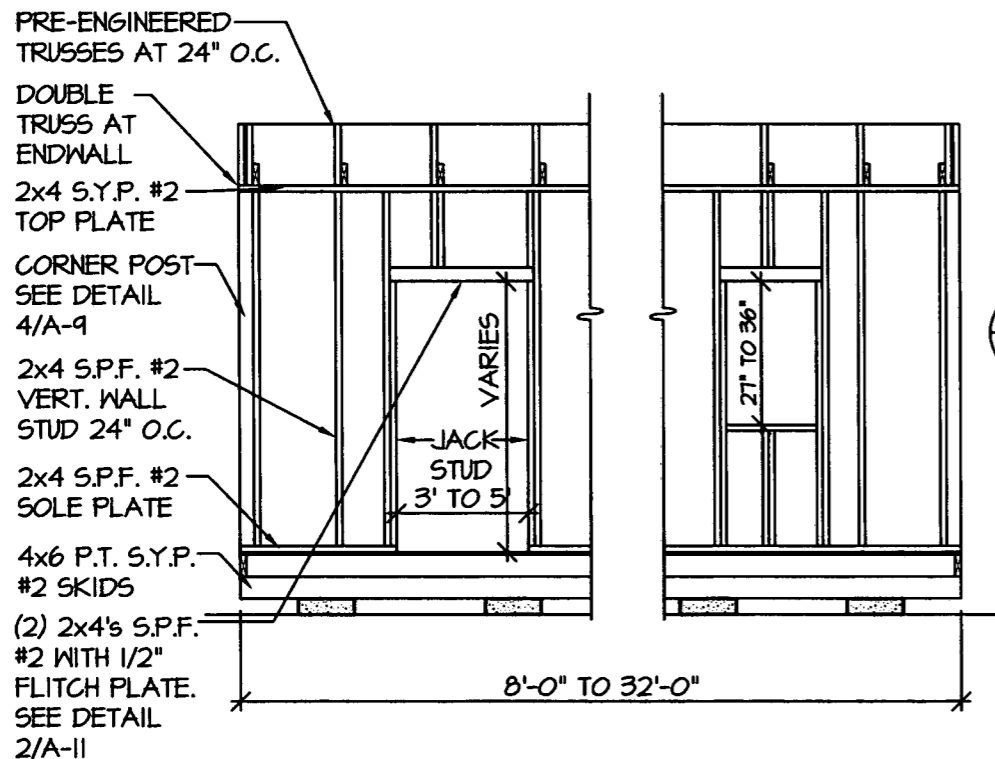

3  
A-6  
SIDEWALL  
**FRAMING ELEVATION**  
SCALE: 1/4" = 1'-0"

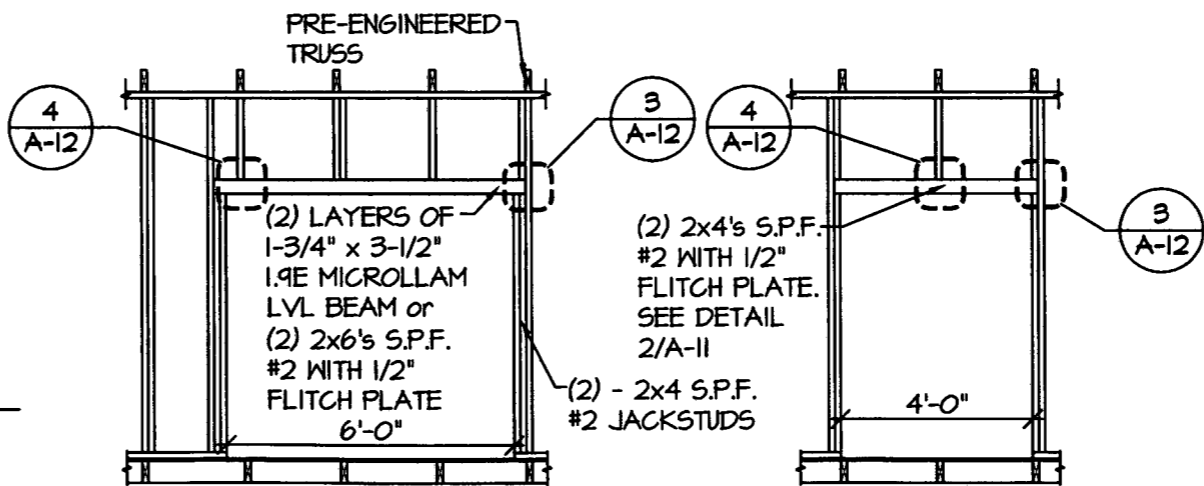

4  
A-6  
SIDEWALL  
6'-0" DOOR HEADER  
**FRAMING ELEVATION**  
SCALE: 1/4" = 1'-0"

5  
A-6  
SIDEWALL  
4'-0" DOOR HEADER  
**FRAMING ELEVATION**  
SCALE: 1/4" = 1'-0"

AREA FOR APPROVAL STAMPS



REV	BY	DATE	DESCRIPTION

THESE PLANS WERE DESIGNED IN ACCORDANCE WITH THE 2012 INTERNATIONAL BUILDING CODE, BUILDING FOR WIND SPEED SECOND GUST OF 160 MPH.

**THOMAS A. DIXON, P.E.**  
 AL# 30631 MS# 19034 KS# 21198  
 SC# 27542 NC# 035485 GA# 034371  
 WV# 071936 TX# 104353 MD# 40905  
 PA# 079009 VA# 045543  
 TN# 112761 FL# 34222  
 DIXON ENGINEERING, INC.  
 STRUCTURAL ENGINEERING AND INSPECTION - COA 8195  
 10410 MAIN STREET  
 THONOTOSASSA, FL 33542  
 VOICE: 813-982-9885 FAX: 813-982-2306

**COOK PORTABLE WAREHOUSES**  
 GARDEN SHED  
 100 DOUGLAS STREET  
 VALDOSTA, GA 31601  
 PHONE: 1-229-241-8805  
**FRAMING ELEVATIONS**

DATE: 03/27/12  
 DRAWN BY: JDA/DGF  
 CHECKED BY: TAD  
 SCALE: AS NOTED  
 W.O. NO: 495-064

SHEET  
**A-6**  
 12 OF 18

This drawing is the property of Dixon Engineering, Inc. Unless otherwise provided for by contract, or other written means, the contents of this drawing are confidential and shall not be transmitted to any other party except as agreed by Dixon Engineering, Inc. Copyright.

**NOTE:**  
FOR ALL FASTENING OF FRAMING MEMBERS NOT NOTED ON THIS SHEET REFER TO FASTENING SCHEDULE ON SHEETS C-4 THRU C-6

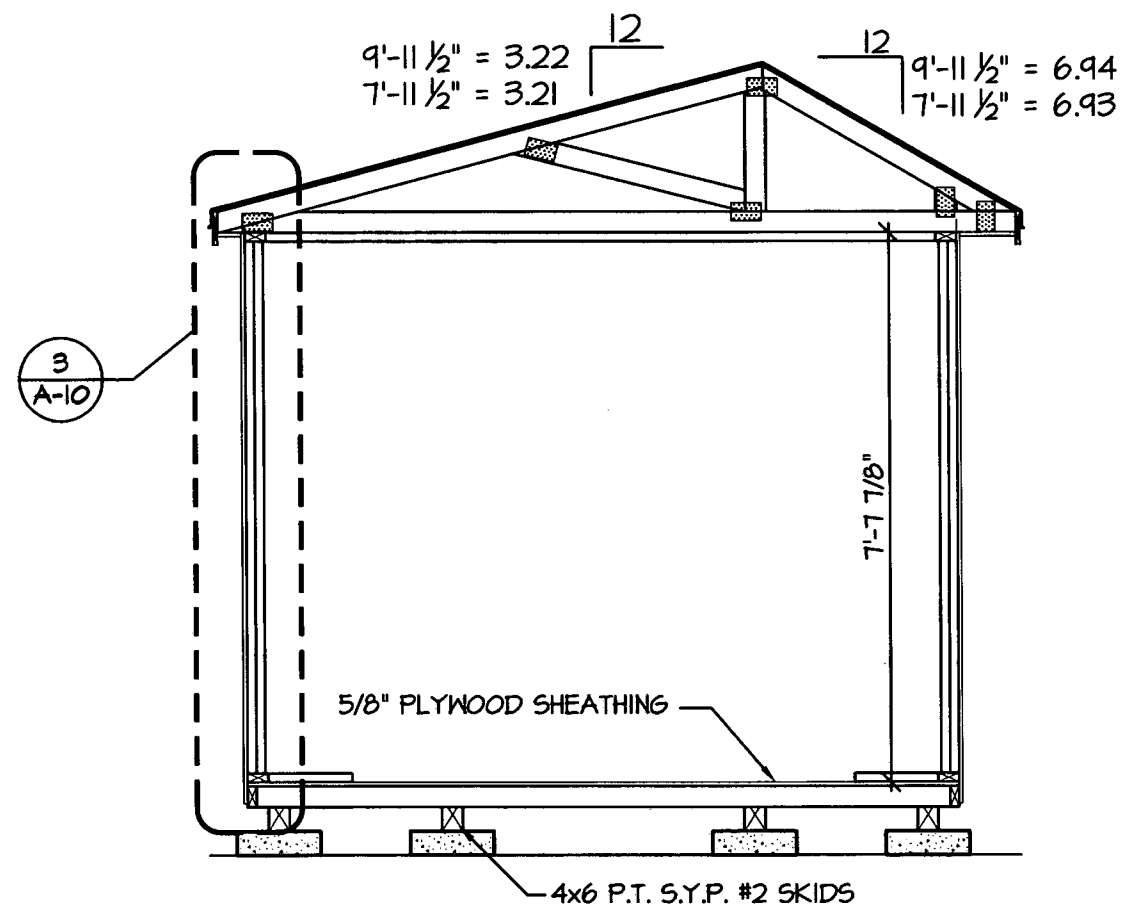

EXAMPLE DRAWING IS OF A 10'-0" WIDE UNIT

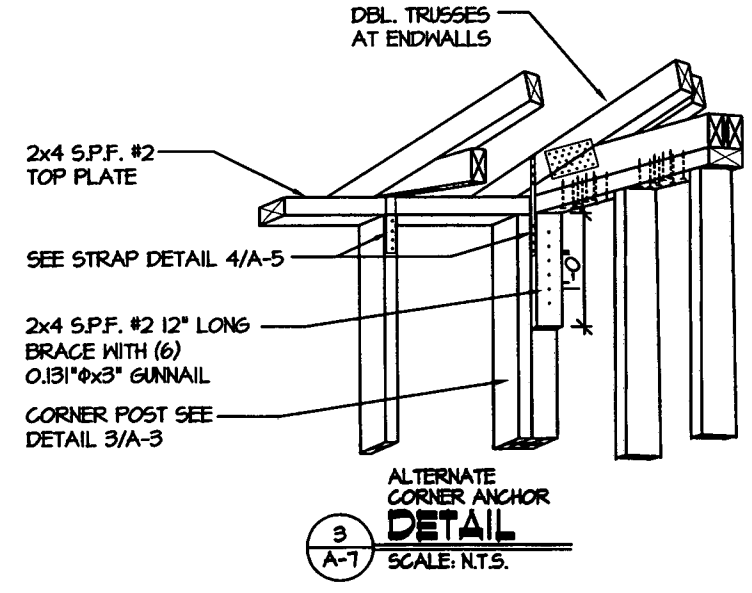
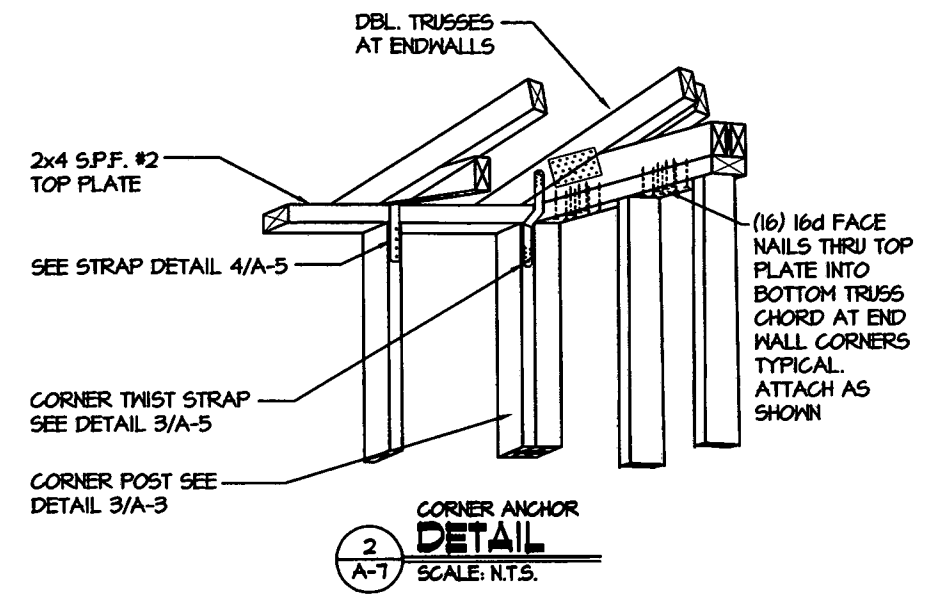

AREA FOR APPROVAL STAMPS



REV	BY	DATE	DESCRIPTION

THESE PLANS WERE DESIGNED IN ACCORDANCE WITH THE 2012 INTERNATIONAL BUILDING CODE, BUILDING CATEGORY II, WIND SPEED SECOND GUST OF 160 MPH.

**THOMAS A. DIXON, P.E.**

AL# 30631 MS# 19034 KS# 21198	DIXON ENGINEERING, INC.
SC# 27542 NC# 035485 GA# 034371	STRUCTURAL ENGINEERING AND INSPECTION - COA 8145
NV# 071936 TX# 104353 MD# 40905	10410 MAIN STREET
PA# 079009 VA# 045543	THONOTOSASSA, FL 33542
TN# 112761 FL# 34222	VOICE: 813-982-9885 FAX: 813-982-2306

**COOK PORTABLE WAREHOUSES**

GARDEN SHED  
 100 DOUGLAS STREET  
 VALDOSTA, GA 31601  
 PHONE: 1-229-241-8805

**SECTION & DETAIL**

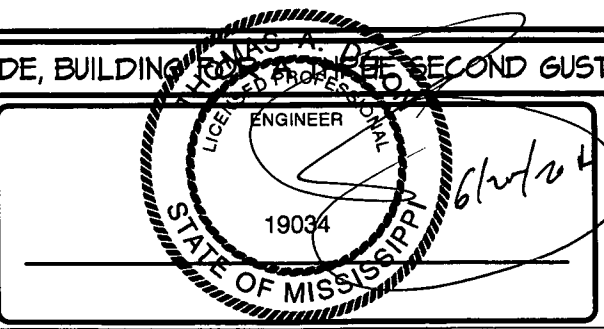

DATE:	03/21/12
DRAWN BY:	JDA/DGF
CHECKED BY:	TAD
SCALE:	AS NOTED
N.O. NO.:	495-064

SHEET  
**A-7**  
 13 OF 18

This drawing is the property of Dixon Engineering, Inc. Unless otherwise provided for by contract, or other written means, the contents of this drawing are confidential and shall not be transmitted to any other party except as agreed by Dixon Engineering, Inc. Copyright.

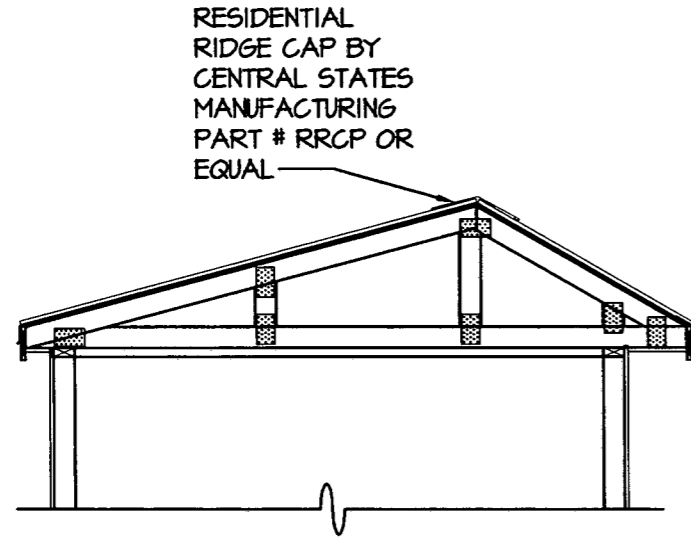

①  
A-B **7'-11" WIDE  
OPTIONAL METAL ROOF  
CROSS SECTION**  
SCALE: 3/8" = 1'-0"

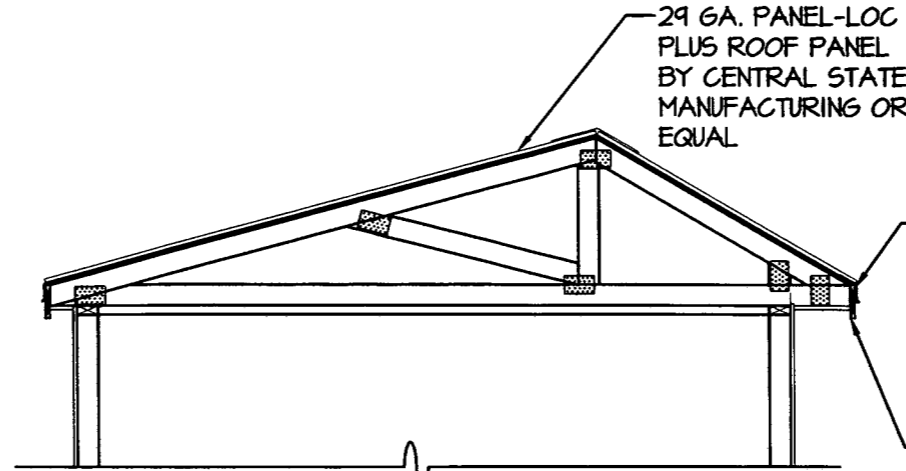

②  
A-B **9'-11" WIDE  
OPTIONAL METAL ROOF  
CROSS SECTION**  
SCALE: 3/8" = 1'-0"

AREA FOR APPROVAL STAMPS



REV	BY	DATE	DESCRIPTION

THESE PLANS WERE DESIGNED IN ACCORDANCE WITH THE 2012 INTERNATIONAL BUILDING CODE, BUILDING WIND SPEED CATEGORY THREE SECOND GUST OF 160 MPH.

**THOMAS A. DIXON, P.E.**

AL# 30631 MS# 19034 KS# 21198  
 SC# 27542 NC# 035405 GA# 034371  
 WV# 071436 TX# 104353 MD# 40905  
 PA# 079009 VA# 045543  
 TN# 112761 FL# 34222

DIXON ENGINEERING, INC.  
 STRUCTURAL ENGINEERING AND INSPECTION - COA 8195  
 10410 MAIN STREET  
 THONOTOSASSA, FL 33542  
 VOICE: 813-982-4885 FAX: 813-982-2306

**COOK PORTABLE WAREHOUSES**  
 GARDEN SHED  
 100 DOUGLAS STREET  
 VALDOSTA, GA 31601  
 PHONE: 1-229-241-8805

**ROOF SECTIONS**

Professional Engineer stamp for Thomas A. Dixon, State of Mississippi, License No. 19034. Includes handwritten date 8/25/12 and signature.

DATE: 03/27/12  
 DRAWN BY: JDA/DGF  
 CHECKED BY: TAD  
 SCALE: AS NOTED  
 W.O. NO: 495-064

This drawing is the property of Dixon Engineering, Inc. Unless otherwise provided for by contract, or other written means, the contents of this drawing are confidential and shall not be transmitted to any other party except as agreed by Dixon Engineering, Inc. Copyright.

AREA FOR APPROVAL STAMPS

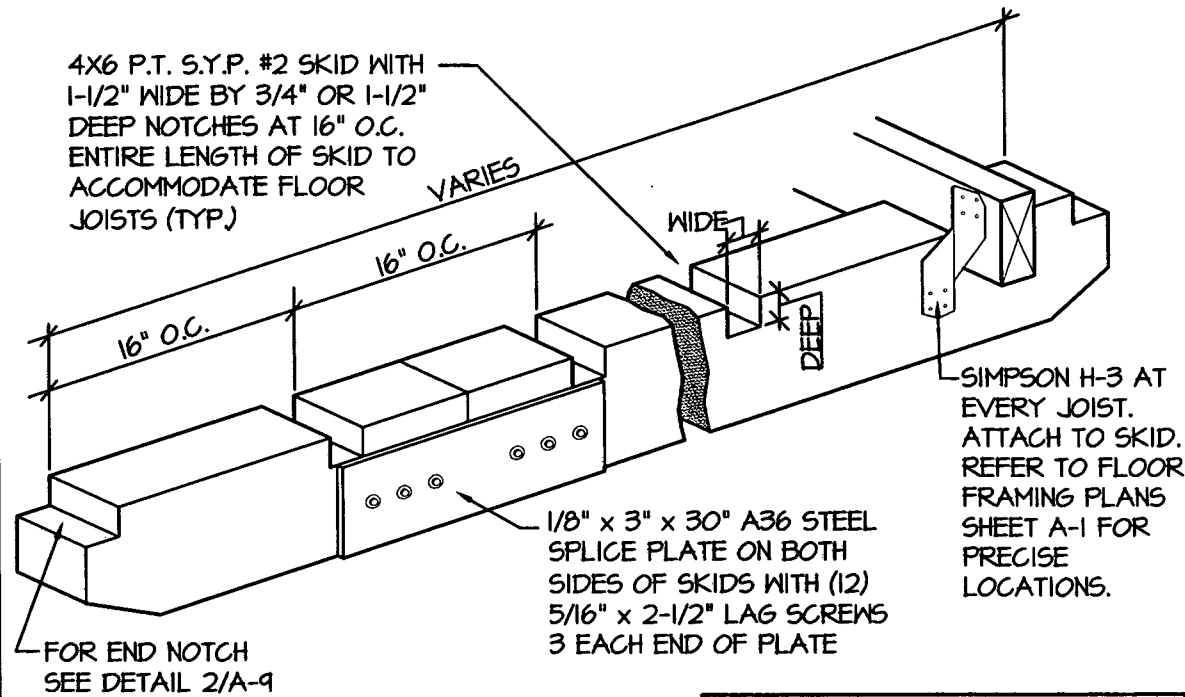
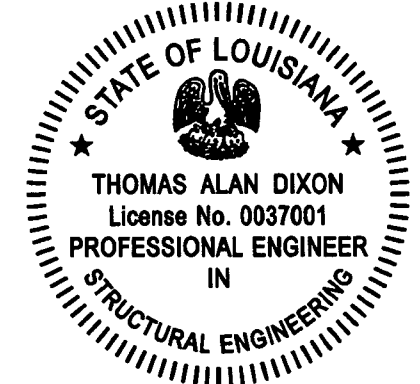

1 ISOMETRIC SKID DETAIL  
A-9 SCALE: N.T.S.

NOTE:  
FOR ALL FASTENING OF FRAMING MEMBERS NOT NOTED ON THIS SHEET REFER TO FASTENING SCHEDULE ON SHEETS C-4 THRU C-6

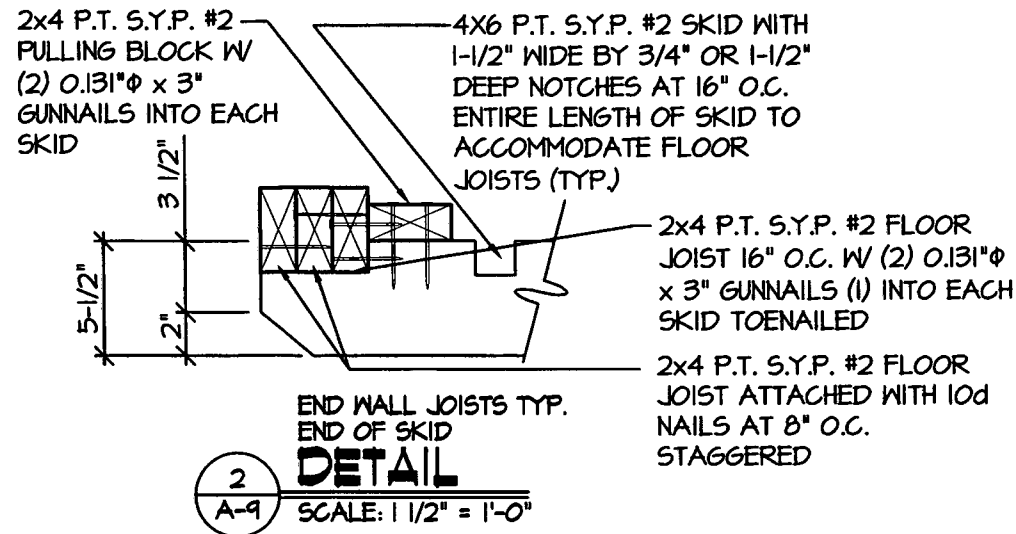

2 END WALL JOISTS TYP. END OF SKID DETAIL  
A-9 SCALE: 1 1/2\"/>

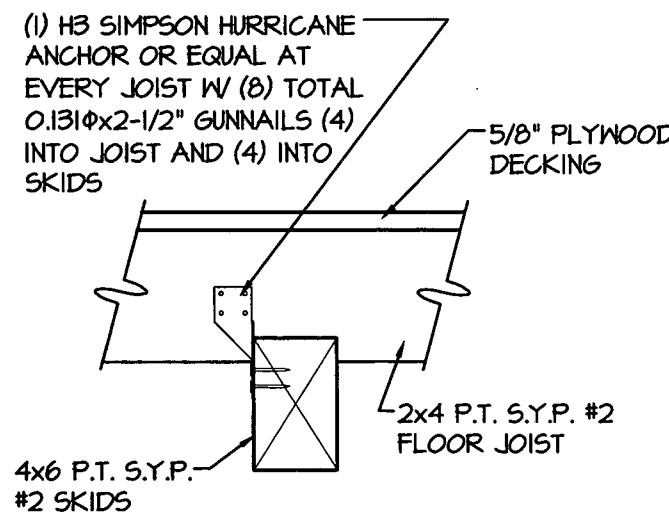

3 SKID CONNECTION DETAIL  
A-9 SCALE: 1 1/2\"/>

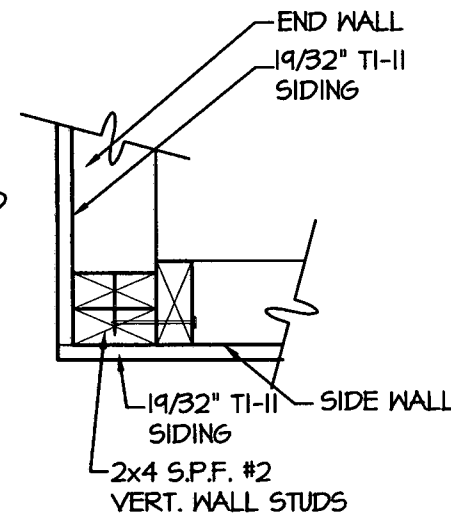

4 CORNER CONNECTION DETAIL  
A-9 SCALE: 1 1/2\"/>

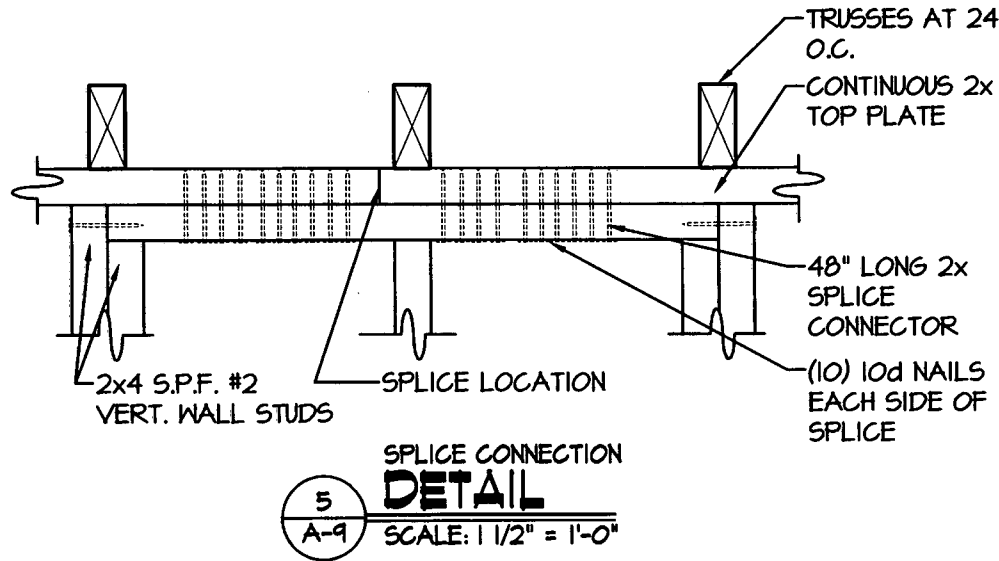
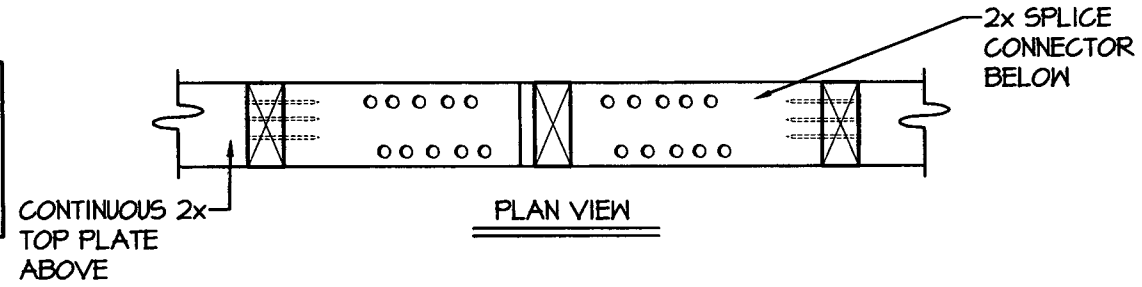

5 SPLICE CONNECTION DETAIL  
A-9 SCALE: 1 1/2\"/>

REV	BY	DATE	DESCRIPTION

THESE PLANS WERE DESIGNED IN ACCORDANCE WITH THE 2012 INTERNATIONAL BUILDING CODE, BUILDING FOR A DESIGN WIND SPEED SECOND GUST OF 160 MPH.

**THOMAS A. DIXON, P.E.**  
 AL# 30637 MS# 19034 KS# 21198 DIXON ENGINEERING, INC.  
 SC# 27592 NC# 035985 GA# 034371 STRUCTURAL ENGINEERING AND INSPECTION - COA 8195  
 WV# 071936 TX# 104353 MD# 40905 10410 MAIN STREET  
 PA# 079009 VA# 045593 THONOTOSASSA, FL 33592  
 TN# 112761 FL# 34222 VOICE: 813-982-9885 FAX: 813-982-2306

**COOK PORTABLE WAREHOUSES**  
 GARDEN SHED  
 100 DOUGLAS STREET  
 VALDOSTA, GA 31601  
 PHONE: 1-229-241-8805  
**DETAILS**

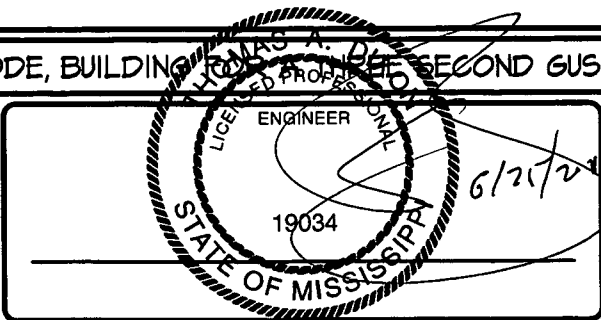

DATE:	03/27/12
DRAWN BY:	JDA/DGF
CHECKED BY:	TAD
SCALE:	AS NOTED
W.O. NO:	495-064

SHEET  
**A-9**  
 15 OF 18

This drawing is the property of Dixon Engineering, Inc. Unless otherwise provided for by contract, or other written means, the contents of this drawing are confidential and shall not be transmitted to any other party except as agreed by Dixon Engineering, Inc. Copyright.

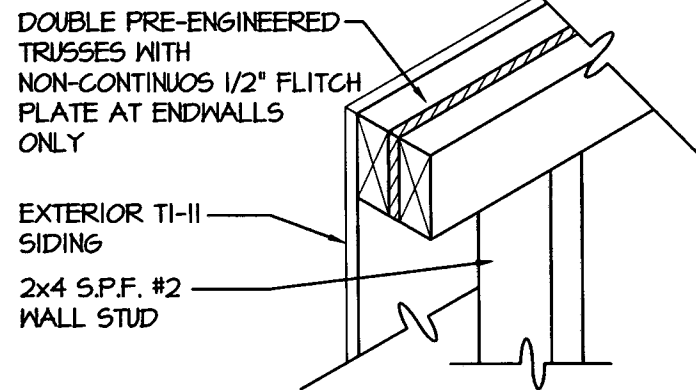

DOUBLE TRUSS DETAIL  
SCALE: 1 1/2" = 1'-0"

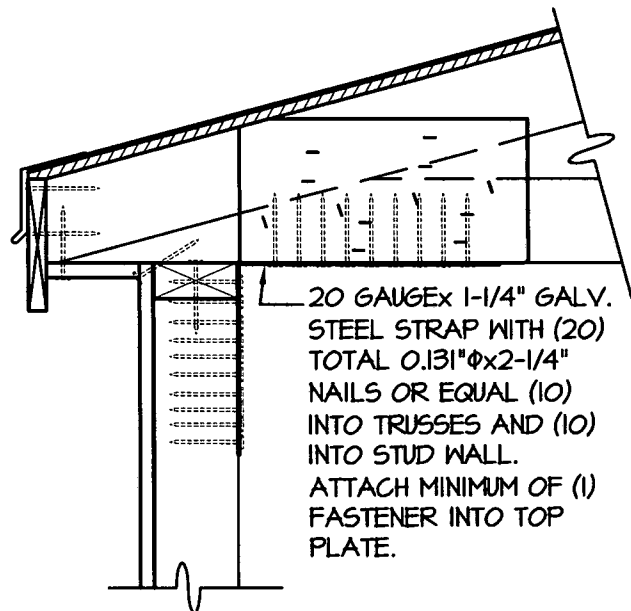

WALL STUD TO RAFTER FASTENING DETAIL  
SCALE: 1 1/2" = 1'-0"

ASTM D 7158 CLASS H OR ASTM D 3161 CLASS F ASPHALT SHINGLES OVER APPROVED UNDERLAYMENT, METHOD OR DESIGN AS DESCRIBED UNDER GENERAL NOTES 10 THRU 13 ON SHEET C-3. FOR METAL ROOFING SEE SHEET A-8 FOR DETAILS

7/16" OSB OR PLYWOOD SHEATHING FASTENED WITH 8D COMMON NAILS AT 6" O.C. IN FIELD AND EDGES ON ALL BUILDINGS WITH SHINGLES OR METAL ROOF COVERING

1x4 S.Y.P. P.T. #2 FASCIA

5/8" PLYWOOD SOFFIT W/ (2) 0.131" diameter x 3" GUNNAILS INTO TRUSSES

SIMPSON MTS12 WITH (14) TOTAL (7) EACH END 0.148" diameter x 1-1/2" GUNNAILS OR EQUAL INTO TRUSSES AND STUD WALLS

2x4 S.P.F. #2 TOP PLATE

NOTE: FOR ALL FASTENING OF FRAMING MEMBERS NOT NOTED ON THIS SHEET REFER TO FASTENING SCHEDULE ON SHEETS C-4 THRU C-6

1 1/8" T1-11 SIDING OR 1 1/8" LP SMARTSIDE PRECISION PANEL SIDING. SEE SHEAR WALL TABLE 1/A-2 FOR MAXIMUM BUILDING LENGTHS BASED ON PRESCRIBED NAILING PATTERN IN ENDWALL SHAER WALLS. NAILING FOR SIDEWALLS SHALL BE 8d COMMON OR DEFORMED NAILS AT 6" O.C. EVERYWHERE.

2x4 S.P.F. #2 VERT. WALL STUD 24" O.C.

2x4 FLOOR JOIST

2x4 BAND JOIST

WALL STUD TO RAFTER AND FLOOR FASTENING DETAIL  
SCALE: 1 1/2" = 1'-0"

AREA FOR APPROVAL STAMPS





REV	BY	DATE	DESCRIPTION

THESE PLANS WERE DESIGNED IN ACCORDANCE WITH THE 2012 INTERNATIONAL BUILDING CODE, BUILDING WIND SPEED CATEGORY 3, WIND SPEED SECOND GUST OF 160 MPH.

**THOMAS A. DIXON, P.E.**  
AL# 306371 MS# 19034 KS# 21198  
SC# 27542 NC# 035485 GA# 034371  
WV# 071936 TX# 104353 MD# 40905  
PA# 079009 VA# 045543  
TN# 112761 FL# 34222  
DIXON ENGINEERING, INC.  
STRUCTURAL ENGINEERING AND INSPECTION - COA 8145  
10410 MAIN STREET  
THONOTOSASSA, FL 33542  
VOICE: 813-982-9885 FAX: 813-982-2306

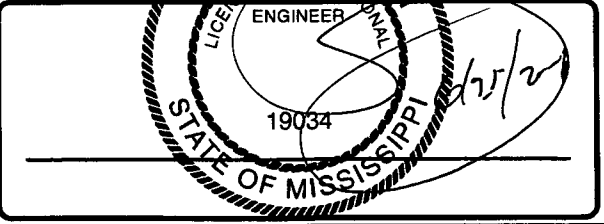
**COOK PORTABLE WAREHOUSES**  
GARDEN SHED  
100 DOUGLAS STREET  
VALDOSTA, GA 31601  
PHONE: 1-229-241-8805  
**DETAILS**



DATE: 03/27/12  
DRAWN BY: JDA/DGF  
CHECKED BY: TAD  
SCALE: AS NOTED  
W.O. NO: 495-064

SHEET  
**A-10**  
16 OF 18



This drawing is the property of Dixon Engineering, Inc. Unless otherwise provided for by contract, or other written means, the contents of this drawing are confidential and shall not be transmitted to any other party except as agreed by Dixon Engineering, Inc. Copyright.

AREA FOR APPROVAL STAMPS



**NOTE:**  
FOR ALL FASTENING OF FRAMING MEMBERS NOT NOTED ON THIS SHEET REFER TO FASTENING SCHEDULE ON SHEETS C-4 THRU C-6

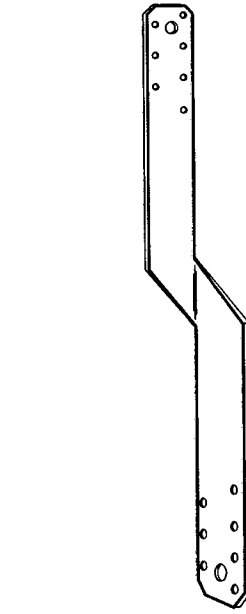

16 GAUGE GALVANIZED STEEL WITH (14) TOTAL (7) EACH END 0.148" $\phi$ x1-1/2" NAILS OR EQUAL INTO RAFTERS AND STUD WALLS

SIMPSON MTS12 OR EQUAL TWIST STRAP  
**DETAIL**

1  
A-II SCALE: 3" = 1'-0"

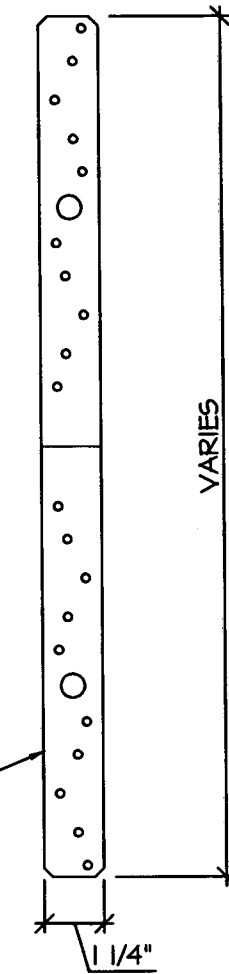

**NOTE:** USED ON EVERY WALL STUD TO CONNECT WALL TO TRUSS

20 GAUGE x 1-1/4" GALV. STEEL STRAP WITH (20) 0.131" $\phi$  x 2-1/4" NAILS OR EQUAL (10) INTO RAFTERS AND (10) INTO STUD WALL

**20 GAGE STRAP DETAIL**

3  
A-II SCALE: 3" = 1'-0"

1/2" FLITCH PLATE

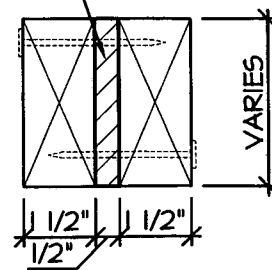

**HEADER SECTION**

2  
A-II SCALE: 3" = 1'-0"

REV	BY	DATE	DESCRIPTION

THESE PLANS WERE DESIGNED IN ACCORDANCE WITH THE 2012 INTERNATIONAL BUILDING CODE, BUILDING FOR WIND SPEEDS TO SECOND GUST OF 160 MPH.

**THOMAS A. DIXON, P.E.**

AL# 30631 MS# 19034 KS# 21198	DIXON ENGINEERING, INC.
SC# 27542 NC# 035405 GA# 034371	STRUCTURAL ENGINEERING AND INSPECTION - COA 0145
WV# 071936 TX# 104353 MD# 40905	10410 MAIN STREET
PA# 079009 VA# 045593	THONOTOSASSA, FL 33542
TN# 112761 FL# 34222	VOICE: 813-982-9885 FAX: 813-982-2306

**COOK PORTABLE WAREHOUSES**  
GARDEN SHED  
100 DOUGLAS STREET  
VALDOSTA, GA 31601  
PHONE: 1-229-241-8805

**DETAILS**

Professional Engineer stamp for Thomas A. Dixon, State of Mississippi, License No. 19034, dated 6/27/2012.

DATE: 03/27/12  
DRAWN BY: JDA/DGF  
CHECKED BY: TAD  
SCALE: AS NOTED  
I.P.O. NO: 495-064

SHEET  
**A-11**  
17 OF 18

This drawing is the property of Dixon Engineering, Inc. Unless otherwise provided for by contract, or other written means, the contents of this drawing are confidential and shall not be transmitted to any other party except as agreed by Dixon Engineering, Inc. Copyright.

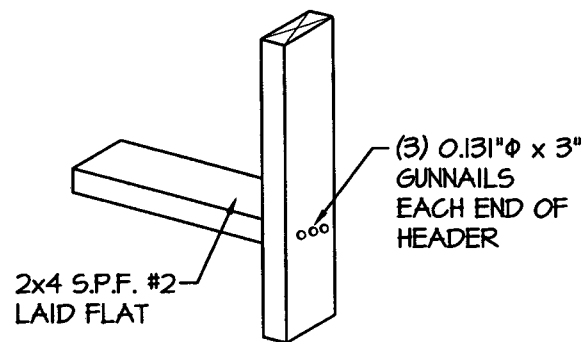

**1**  
A-12  
**WINDOW HEADER AND SILL DETAIL**  
SCALE: N.T.S.

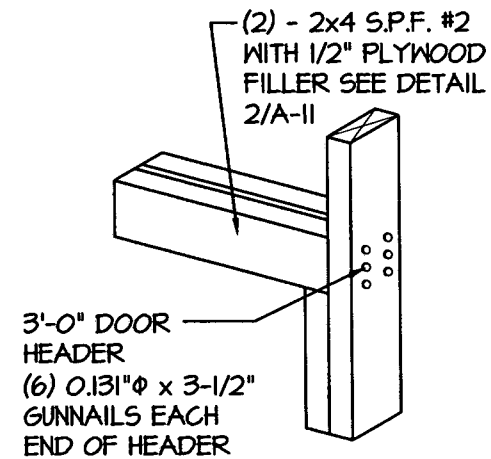

**2**  
A-12  
**HEADER WITH OUT STRAP DETAIL**  
SCALE: N.T.S.

**NOTE:**  
FOR ALL FASTENING OF FRAMING MEMBERS NOT NOTED ON THIS SHEET REFER TO FASTENING SCHEDULE ON SHEETS C-4 THRU C-6

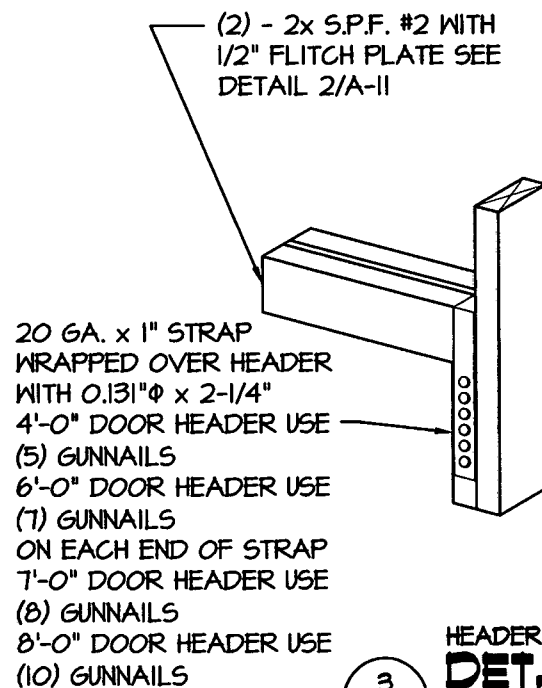

**3**  
A-12  
**HEADER WITH STRAP DETAIL**  
SCALE: N.T.S.

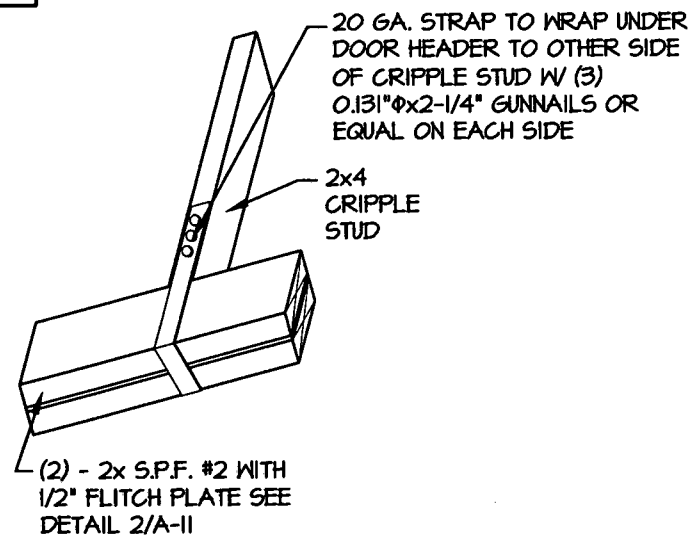

**4**  
A-12  
**CRIPPLE STUD STRAP DETAIL**  
SCALE: N.T.S.

AREA FOR APPROVAL STAMPS

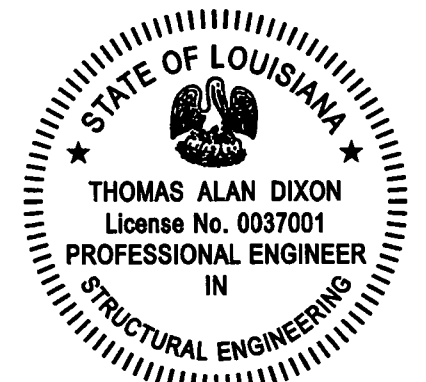

REV	BY	DATE	DESCRIPTION

THESE PLANS WERE DESIGNED IN ACCORDANCE WITH THE 2012 INTERNATIONAL BUILDING CODE, BUILDING FOR WIND SPEEDS TO THE SECOND GUST OF 160 MPH.

**THOMAS A. DIXON, P.E.**

AL# 30637 MS# 19034 KS# 21198  
 SC# 27542 NC# 035985 GA# 034371  
 WV# 071936 TX# 104353 MD# 40905  
 PA# 079009 VA# 045543  
 TN# 112761 FL# 34222

DIXON ENGINEERING, INC.  
 STRUCTURAL ENGINEERING AND INSPECTION - COA 8195  
 10410 MAIN STREET  
 THONOTOSASSA, FL 33542  
 VOICE: 813-982-9885 FAX: 813-982-2306

**COOK PORTABLE WAREHOUSES**  
 GARDEN SHED  
 100 DOUGLAS STREET  
 VALDOSTA, GA 31601  
 PHONE: 1-229-241-8805

**DETAILS**

1/25/12

DATE: 03/21/12  
 DRAWN BY: JDA/DGF  
 CHECKED BY: TAD  
 SCALE: AS NOTED  
 N.O. NO: 495-064

SHEET  
**A-12**  
 18 OF 18