

COOK PORTABLE WAREHOUSES

100 DOUGLAS ST. VALDOSTA, GA 31601
132 CENTRAL INDUSTRIAL ROW, PURVIS, MS 39475
1398 HWY 95 NORTH, BASTROP, TX 78602

TIEDOWN PLANS

STATE OF
FLORIDA

GENERAL NOTES

1. THE CONTRACTOR SHALL BE RESPONSIBLE FOR VERIFYING ALL EXISTING CONDITIONS.
2. THE CONTRACTOR SHALL BE RESPONSIBLE FOR COORDINATING ARCHITECTURAL, STRUCTURAL, MECHANICAL, AND ELECTRICAL DETAIL AND DIMENSIONS. ANY DISCREPANCIES BETWEEN SUCH DETAILS AND DIMENSIONS SHALL BE REPORTED TO THE ENGINEER PRIOR TO PROCEEDING WITH THE WORK.
3. THE CONTRACTOR SHALL BE RESPONSIBLE FOR ERECTION PROCEDURE AND SEQUENCE TO INSURE THE INTEGRITY OF THE BUILDING AND ITS COMPONENT PARTS DURING CONSTRUCTION.
4. THESE PLANS HAVE BEEN PREPARED PER REGULATIONS OF THE 6TH EDITION, 2017 FLORIDA BUILDING CODE. THE WORK OF ALL CONTRACTORS SHALL COMPLY WITH THE REQUIREMENTS SET FORTH IN THE AFOREMENTIONED CODE. NO DEVIATIONS FROM THE WORK SHOWN OR REASONABLY IMPLIED SHALL BE UNDERTAKEN WITHOUT THE ENGINEERS WRITTEN CONSENT - A COPY OF WHICH WILL BE FILED WITH THE CONSTRUCTION OFFICIAL.
5. ANY CHANGES TO OR DEVIATIONS FROM THESE DRAWINGS SHALL NOT BE MADE WITHOUT WRITTEN CONSENT FROM THE ENGINEER.
6. THESE DRAWINGS ARE THE PROPERTY OF THE ENGINEER AND SHALL NOT BE USED WITHOUT HIS CONSENT. DRAWINGS SHALL NOT BE USED FOR ISSUE OF BUILDING PERMIT UNLESS SIGNED AND SEALED BY THE ENGINEER.
7. THE OWNER AND THE CONTRACTOR SHALL HOLD HARMLESS THE ENGINEER FROM AND AGAINST ALL LIABILITY CLAIMS, DAMAGES, LOSSES, AND EXPENSES INCLUDING LEGAL FEES ARISING OUT OF OR RESULTING FROM ERRORS OR OMISSIONS IN THE PERFORMANCE OF THE WORK BY THE CONTRACTOR. THE DRAWINGS SHOW THE GENERAL ARRANGEMENTS AND EXTENT OF THE WORK. AS THE WORK PROGRESSES, THE OWNER AND THE CONTRACTOR, AT NO EXTRA COSTS, SHALL MAKE THE MODIFICATIONS TO MAKE THE PARTS ALIGN.
8. ALL WORK AND MATERIALS SHALL MEET THE REQUIREMENTS OF LOCAL AND STATE CODES AND THE SPECS OF THE NATIONAL BOARD OF FIRE UNDERWRITERS. CONTRACTORS SHALL CHECK AND VERIFY ALL PLAN DIMENSIONS AND CONDITIONS BEFORE PROCEEDING WITH CONSTRUCTION. HE SHALL REPORT ANY DISCREPANCIES TO THE ENGINEER FOR CORRECTION PRIOR TO BEGINNING ANY WORK. THE DISCOVERY OF DISCREPANCIES AFTER THE BEGINNING OF WORK WILL BE EVIDENCE OF FAULTY WORK. AND SHALL BE THE RESPONSIBILITY OF THE CONTRACTOR. DO NOT SCALE DRAWINGS. ALL WRITTEN DIMENSIONS GOVERN.
9. THE CONTRACTOR FOR THIS PROJECT SHALL INCLUDE ALL MATERIALS AND LABOR REQUIRED TO COMPLETE THE TOTAL PROJECT. THE CONTRACTOR SHALL FURNISH AND PAY FOR ALL MATERIALS. TOOLS, EQUIPMENT, LABOR, MACHINERY, TRANSPORTATION, HEAT, WATER, UTILITIES, AND ALL OTHER FACILITIES AND SERVICES REQUIRED FOR THE SAFE AND PROPER EXECUTION AND COMPLETION OF THE WORK.
10. THE DOCUMENTS SHOW AN OVERVIEW OF THE WORK REQUIRED UNDER THIS CONTRACT AND RELATED REQUIREMENTS AND CONDITIONS THAT WILL IMPACT THE PROJECT. ALL DRAWINGS ARE COMPLIMENTARY. THE DRAWINGS GENERALLY SHOW THE INTENT OF THE OVERALL COMPLEXITY AND CONCEPTS OF THE PROJECT, AND DO NOT NECESSARILY SHOW ALL DETAILS AND CONDITIONS. ALL NEW INTERIOR CONCRETE SLABS AND FOUNDATION WALLS AND FOOTINGS SHALL HAVE SOIL POISONING UNDER NEW WORK AND SHALL BE INSTALLED BY A LICENSED CONTRACTOR.
11. ALL WORK SHALL BE COMPLETED IN ACCORDANCE WITH ALL STATE AND DEPARTMENT OF AGRICULTURE, STRUCTURAL PEST CONTROL DIVISION REGULATIONS, RULES DEFINITIONS AND REQUIREMENTS.
12. THE CONTRACTOR SHALL BE RESPONSIBLE FOR VERIFYING AND MAINTAINING ALL EXISTING SETBACKS, EASEMENTS, AND ANY DEED RESTRICTIONS.
13. THE CONTRACTOR SHALL BE RESPONSIBLE FOR FINAL CLEANUP AND SHALL INCLUDE THE SITE, AND THE BUILDING. THE ENTIRE PROJECT SHALL BE LEFT IN A NEW, CLEAN CONDITION.
14. TIEDOWNS SHOWN INCLUDING STRAP AND ANCHOR, AND BEARING PADS ARE BASED ON AN ALLOWABLE BEARING PRESSURE OF 2500 PSF. ANY SOIL CONDITIONS THAT MAY DIFFER FROM THIS MUST BE BROUGHT TO THE ATTENTION OF THE ENGINEER.
15. THE CONTRACTOR IS RECOMMENDED TO USE A SOIL TEST PROBE TO DETERMINE THE SOIL CLASS. WHERE SUCH TESTING IS NOT CONDUCTED, IT IS RECOMMENDED TO USE A 60" GALVANIZED ANCHOR WITH STABILIZER PLATE.
16. CONCRETE PADS UNDER SKIDS ARE OPTIONAL AND SHALL BE LOCATED ON UNDISTURBED SOIL OR PROPERLY COMPACTED FILL MATERIAL. COMPACTED SOIL SHALL BE TESTED TO A MINIMUM OF 95% PROCTOR IN ACCORDANCE WITH ASTM D1557. FILL MATERIAL SHALL BE FREE OF VEGETATION AND FOREIGN MATERIAL.
17. FINISH GRADE SHALL BE SLOPED AWAY FROM THE FOUNDATION FOR DRAINAGE. PROVISIONS SHALL BE MADE TO PREVENT SOIL EROSION UNDER THE PAD AND DIRECT WATER AWAY FROM IT.

Sheet Index

SHEET NUMBER	SHEET TITLE
F-1	TIEDOWN GENERAL NOTES
F-2	TIEDOWN SCHEDULE FOR EXPOSURE B
F-3	TIEDOWN SCHEDULE FOR EXPOSURE C
F-4	GROUND ANCHOR SCHEDULE
F-5	TIEDOWN SECTIONS
F-6	OPTIONAL PAD DETAILS

Engineer: Kent Bice
FL License #: 50421
COA# 30468

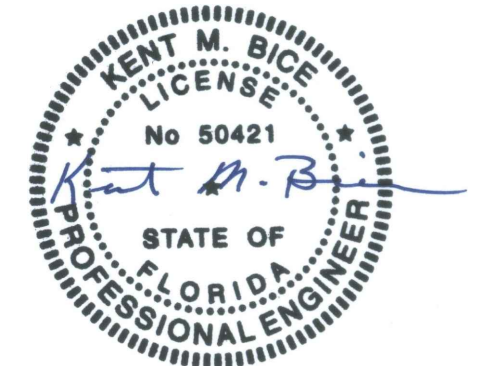

04/12/18

1552 6TH ST., WINTER HAVEN, FL 33880
(863)865-6502

GENERAL NOTES

DATE: 04/10/18

DRAWN BY: RD

SCALE: AS NOTED

CHECKED BY: KMB

SHEET:

F-1

SHEET 1 OF 6

THESE PLANS WERE DESIGNED IN ACCORDANCE WITH THE 6TH EDITION, 2017 FLORIDA BUILDING CODE.

TIEDOWN SCHEDULE FOR UP TO 110 MPH WIND SPEED, EXPOSURE "B"													
BLDG WIDTH	NUMBER OF TIEDOWNS PER OUTER SKID BY BUILDING LENGTH (FT)												
	8'-0"	10'-0"	12'-0"	14'-0"	16'-0"	18'-0"	20'-0"	22'-0"	24'-0"	26'-0"	28'-0"	30'-0"	32'-0"
6'-0"	2	2	2	N/A	N/A	N/A	N/A	N/A	N/A	N/A	N/A	N/A	N/A
7'-11" 1/2"	2	2	2	2	2	2	2	2	2	N.A.	N.A.	N.A.	N.A.
9'-11" 1/2"	2	2	2	2	2	2	2	2	2	2	2	2	N.A.
11'-0"	2	2	2	2	2	2	2	2	2	2	2	2	2

TIEDOWN SCHEDULE FOR 111 TO 130 MPH WIND SPEED, EXPOSURE "B"													
BLDG WIDTH	NUMBER OF TIEDOWNS PER OUTER SKID BY BUILDING LENGTH (FT)												
	8'-0"	10'-0"	12'-0"	14'-0"	16'-0"	18'-0"	20'-0"	22'-0"	24'-0"	26'-0"	28'-0"	30'-0"	32'-0"
6'-0"	2	2	2	N/A	N/A	N/A	N/A	N/A	N/A	N/A	N/A	N/A	N/A
7'-11" 1/2"	2	2	2	2	2	2	2	2	2	N.A.	N.A.	N.A.	N.A.
9'-11" 1/2"	2	2	2	2	2	2	2	2	2	2	2	2	N.A.
11'-0"	2	2	2	2	2	2	2	2	2	2	2	2	2

TIEDOWN SCHEDULE FOR 131 TO 160 MPH WIND SPEED, EXPOSURE "B"													
BLDG WIDTH	NUMBER OF TIEDOWNS PER OUTER SKID BY BUILDING LENGTH (FT)												
	8'-0"	10'-0"	12'-0"	14'-0"	16'-0"	18'-0"	20'-0"	22'-0"	24'-0"	26'-0"	28'-0"	30'-0"	32'-0"
6'-0"	2	2	2	N/A	N/A	N/A	N/A	N/A	N/A	N/A	N/A	N/A	N/A
7'-11" 1/2"	2	2	2	2	2	2	3	3	3	N.A.	N.A.	N.A.	N.A.
9'-11" 1/2"	2	2	2	2	2	2	2	3	3	3	3	3	N.A.
11'-0"	2	2	2	2	2	2	2	3	3	3	3	3	4

1. PROVIDE A MINIMUM OF ONE TIEDOWN STRAP AND ANCHOR AT EACH END OF EACH OUTER SKID. EVENLY SPACE THE REMAINING TIEDOWNS.
2. WRAP THE STRAP AROUND THE SKID AND ATTACH TO ANCHOR.
3. MAXIMUM PERMITTED ANGLE OF STRAP FROM VERTICAL IS 45 DEGREES. LOCATE ANCHORS VERTICALLY INTO THE GROUND.

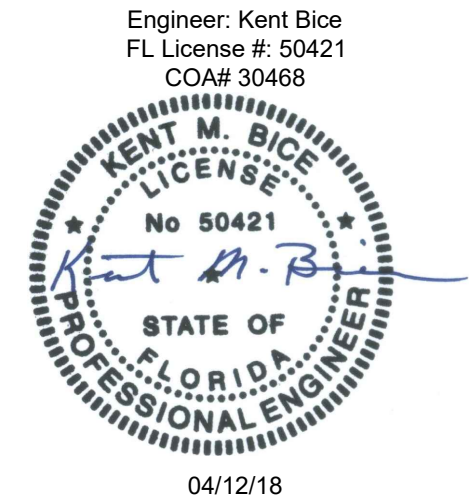

1552 6TH ST., WINTER HAVEN, FL 33880
 (863)865-6502

TIEDOWN SCHEDULE FOR EXPOSURE B	
DATE: 04/10/18	DRAWN BY: RD
SCALE: AS NOTED	CHECKED BY: KMB

SHEET:
F-2
 SHEET 2 OF 6

THESE PLANS WERE DESIGNED IN ACCORDANCE WITH THE 6TH EDITION, 2017 FLORIDA BUILDING CODE.

TIEDOWN SCHEDULE FOR UP TO 110 MPH WIND SPEED, EXPOSURE "C"													
BLDG WIDTH	NUMBER OF TIEDOWNS PER OUTER SKID BY BUILDING LENGTH (FT)												
	8'-0"	10'-0"	12'-0"	14'-0"	16'-0"	18'-0"	20'-0"	22'-0"	24'-0"	26'-0"	28'-0"	30'-0"	32'-0"
6'-0"	2	2	2	N/A	N/A	N/A	N/A	N/A	N/A	N/A	N/A	N/A	N/A
7'-11" 1/2"	2	2	2	2	2	2	2	2	2	N.A.	N.A.	N.A.	N.A.
9'-11" 1/2"	2	2	2	2	2	2	2	2	2	2	2	2	N.A.
11'-0"	2	2	2	2	2	2	2	2	2	2	2	2	2

TIEDOWN SCHEDULE FOR 111 TO 130 MPH WIND SPEED, EXPOSURE "C"													
BLDG WIDTH	NUMBER OF TIEDOWNS PER OUTER SKID BY BUILDING LENGTH (FT)												
	8'-0"	10'-0"	12'-0"	14'-0"	16'-0"	18'-0"	20'-0"	22'-0"	24'-0"	26'-0"	28'-0"	30'-0"	32'-0"
6'-0"	2	2	2	N/A	N/A	N/A	N/A	N/A	N/A	N/A	N/A	N/A	N/A
7'-11" 1/2"	2	2	2	2	2	2	2	2	2	N.A.	N.A.	N.A.	N.A.
9'-11" 1/2"	2	2	2	2	2	2	2	2	2	2	3	3	N.A.
11'-0"	2	2	2	2	2	2	2	2	2	2	3	3	3

TIEDOWN SCHEDULE FOR 131 TO 160 MPH WIND SPEED, EXPOSURE "C"													
BLDG WIDTH	NUMBER OF TIEDOWNS PER OUTER SKID BY BUILDING LENGTH (FT)												
	8'-0"	10'-0"	12'-0"	14'-0"	16'-0"	18'-0"	20'-0"	22'-0"	24'-0"	26'-0"	28'-0"	30'-0"	32'-0"
6'-0"	2	2	2	N/A	N/A	N/A	N/A	N/A	N/A	N/A	N/A	N/A	N/A
7'-11" 1/2"	2	2	2	3	3	3	4	4	4	N.A.	N.A.	N.A.	N.A.
9'-11" 1/2"	2	2	2	2	2	3	3	3	3	3	4	4	N.A.
11'-0"	2	2	2	2	2	3	3	3	3	3	4	4	4

1. PROVIDE A MINIMUM OF ONE TIEDOWN STRAP AND ANCHOR AT EACH END OF EACH OUTER SKID. EVENLY SPACE THE REMAINING TIEDOWNS.
2. WRAP THE STRAP AROUND THE SKID AND ATTACH TO ANCHOR.
3. 3. MAXIMUM PERMITTED ANGLE OF STRAP FROM VERTICAL IS 45 DEGREES. LOCATE ANCHORS VERTICALLY INTO THE GROUND.

Engineer: Kent Bice
 FL License #: 50421
 COA# 30468

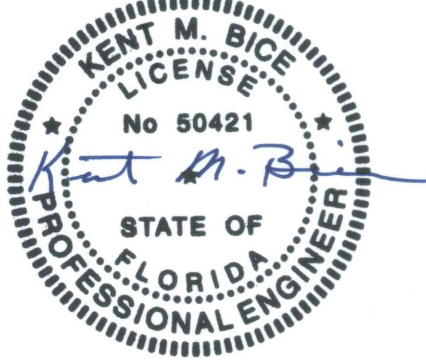

04/12/18

1552 6TH ST., WINTER HAVEN, FL 33880
 (863)865-6502

TIEDOWN SCHEDULE FOR EXPOSURE C		SHEET: F-3 SHEET 3 OF 6
DATE: 04/10/18	DRAWN BY: RD	
SCALE: AS NOTED	CHECKED BY: KMB	

THESE PLANS WERE DESIGNED IN ACCORDANCE WITH THE 6TH EDITION, 2017 FLORIDA BUILDING CODE.

GROUND ANCHOR SCHEDULE			
MODEL #	PART #	DESCRIPTION	SOIL CLASS
M12H5/8	59080 / 59081	48" X 5/8" ROD WITH (1) 6" HELIX	4A
M12H3/4	59085 / 59094	48" X 3/4" ROD WITH (1) 6" HELIX	4A
M1423/4	59128	42" X 3/4" ROD WITH (2) 4" HELIX	4A
M1483/4	59086	48" X 3/4" ROD WITH (2) 4" HELIX	4A
M12H64	59250	36" X 3/4" ROD WITH (1) 4" HELIX AND (1) 6" HELIX	4A
N/A	59065	EYE ANCHOR - 48" X 5/8" WITH (1) 6" HELIX	4A
N/A	59045	EYE ANCHOR - 48" X 3/4" WITH (1) 6" HELIX	4A
M607	59099	60" X 3/4" WITH (1) 7" HELIX	4B
N/A	59040	EYE ANCHOR - 60" X 3/4" WITH (1) 8" HELIX	4B

NOTES:

1. ALL APPROVED ANCHORS LISTED ABOVE ARE MANUFACTURED BY TIE DOWN ENGINEERING.
2. THE CONTRACTOR MAY USE AN APPROVED EQUIVALENT WITH APPROVAL FROM THE EOR.
3. ANCHORS SHALL BE INSTALLED PER MANUFACTURER INSTRUCTIONS.

Engineer: Kent Bice
 FL License #: 50421
 COA# 30468



04/12/18

1552 6TH ST., WINTER HAVEN, FL 33880
 (863)865-6502

GROUND ANCHOR SCHEDULE

DATE: 04/10/18	DRAWN BY: RD
SCALE: AS NOTED	CHECKED BY: KMB

SHEET:
F-4
 SHEET 4 OF 6

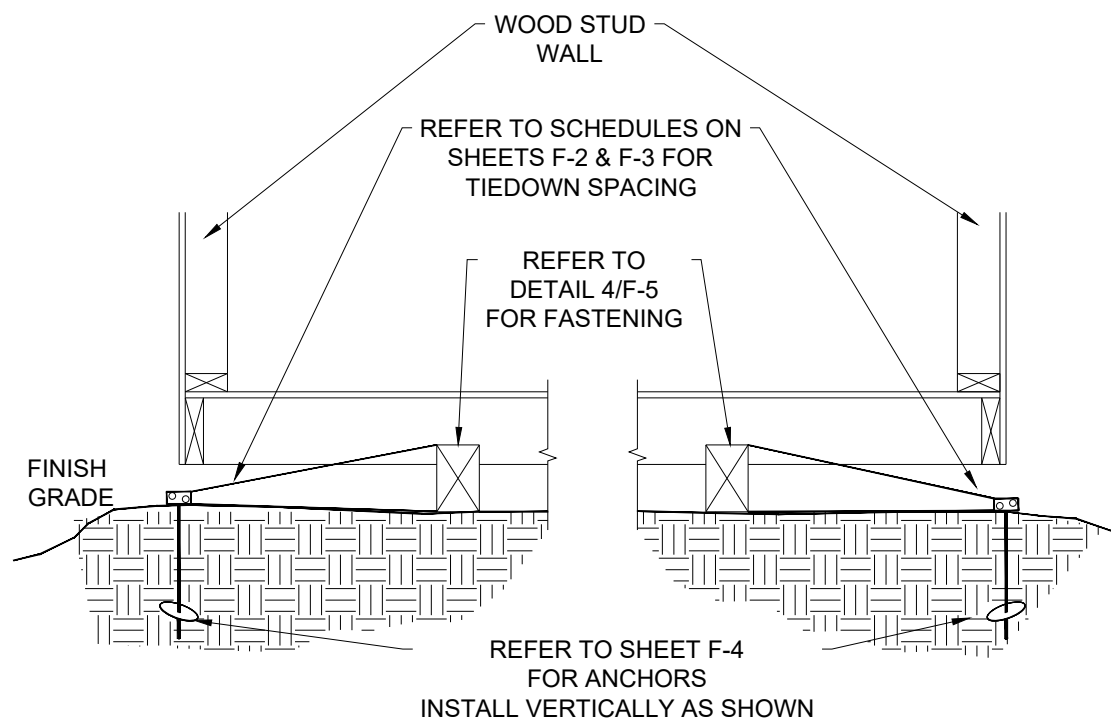

1
F-5 **ALL SKIDS ON GRADE VERTICAL ANCHOR SECTION**
SCALE: N.T.S.

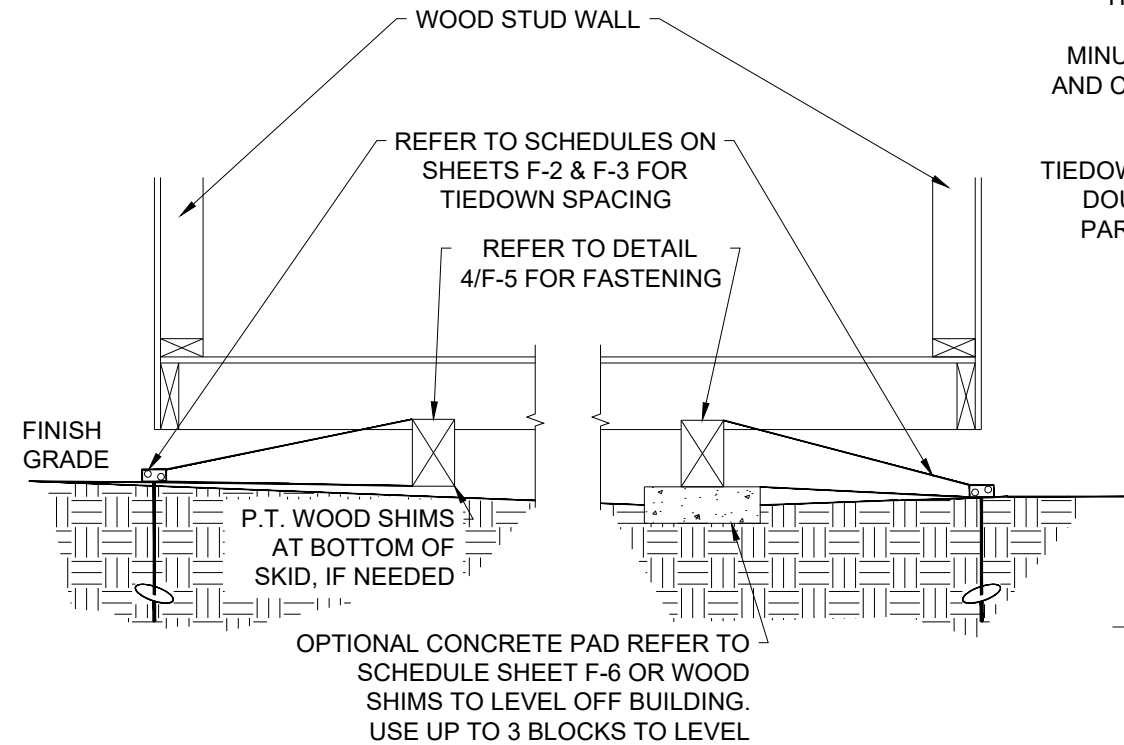

2
F-5 **SKIDS ON GRADE & CONC. PADS VERTICAL ANCHOR UN-LEVEL GROUND SECTION**
SCALE: N.T.S.

TIEDOWN STRAP - 0.035 x 1-1/4" GALVANIZED STEEL QQS-781-H 1 FINISH B, GRADE 1 BY MINUTEMAN PRODUCTS INC. OR EQUAL. STRAP AND CONNECTION HARDWARE SHALL HAVE 4725 LB. MIN. ULTIMATE CAPACITY

TIEDOWN ENGINEERING DOUBLE TENSIONER PART NUMBER 59100

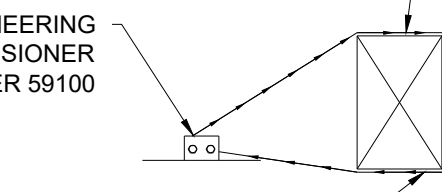

BUILDING SKID REFER TO BUILDING PLAN FOR SIZE, LENGTH, AND LOCATION

4
F-5 **DETAIL**
SCALE: N.T.S.

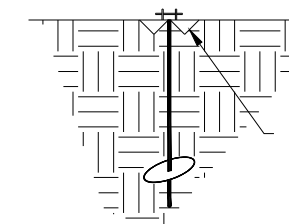

STABILIZER PLATE #59286 FOR CLASS 4 SOILS OR #59292 BY TIE DOWN ENGINEERING OR EQUAL, AT ALL ANCHOR LOCATIONS EACH SIDE OF SHED, IF REQUIRED

5
F-5 **STABILIZER PLATE DETAIL**
SCALE N.T.S.

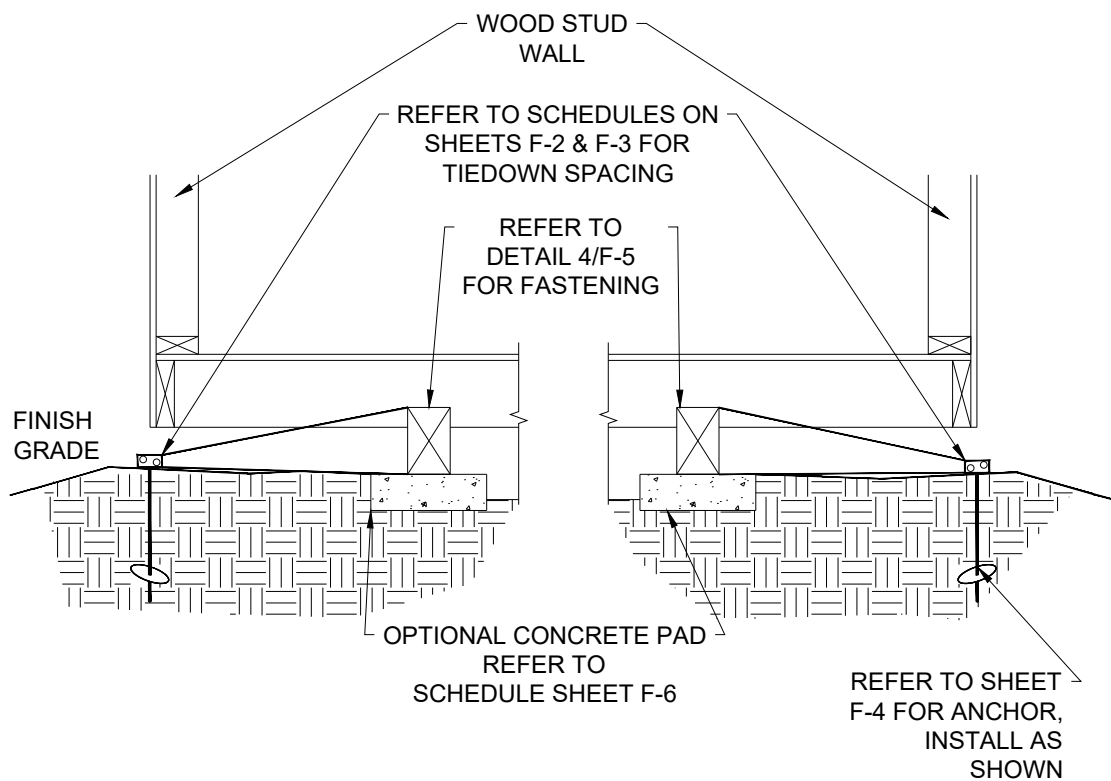

3
F-5 **ALL SKIDS ON CONC. PADS VERTICAL ANCHOR SECTION**
SCALE: N.T.S.

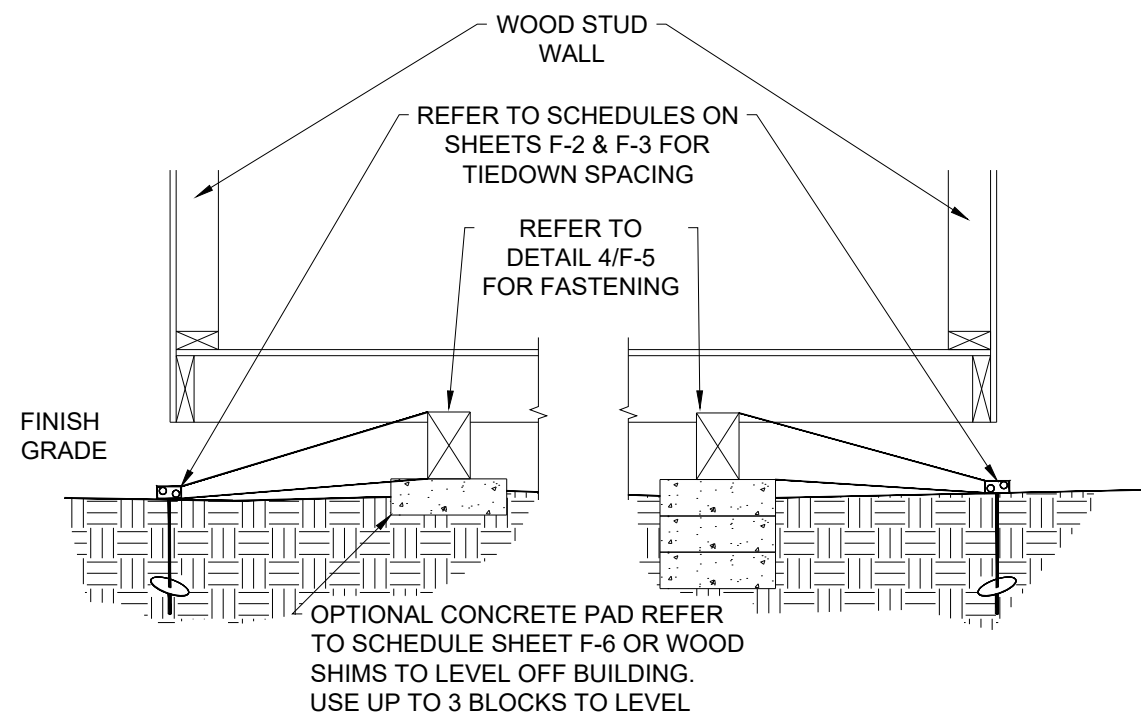

6
F-5 **ALL SKIDS ON CONC. PADS VERTICAL ANCHOR UN-LEVEL GROUND SECTION**
SCALE N.T.S.

Engineer: Kent Bice
FL License #: 50421
COA# 30468



04/12/18

1552 6TH ST., WINTER HAVEN, FL 33880
(863)865-6502

TIEDOWN SECTIONS

DATE: 04/10/18

DRAWN BY: RD

SCALE: AS NOTED

CHECKED BY: KMB

SHEET:

F-5

SHEET 5 OF 6

NOTE:

1. 4" MIN. THICK, 2500 PSI MIN. CONCRETE PADS ARE OPTIONAL.
2. DIMENSIONS SHOWN ARE NOMINAL.
3. TIEDOWNS ARE REQUIRED MIN. (4) PER BUILDING, (1) AT EACH CORNER SHEARWALL (SW#).
4. REFER TO SCHEDULES ON SHEET F-2 & F-3 FOR TIEDOWN SPACING AND SCHEDULES ON THIS SHEET FOR OPTIONAL PAD LOCATION.
5. SPACE OPTIONAL PADS AT EACH END OF EACH SKID AND EQUALLY IN-BETWEEN.
6. LOCATE PAD CENTERED UNDER THE SKID.

16" X 16" X 4" OR (2) 16" X 8" X 4" PAD SCHEDULE FOR ALL WIND SPEEDS, EXPOSURES, AND 40 PSF FLOOR LOAD

BLDG WIDTH	NUMBER OF PADS REQUIRED BY BUILDING LENGTH UNDER EACH SKID													
	8'-0"	10'-0"	12'-0"	14'-0"	16'-0"	18'-0"	20'-0"	22'-0"	24'-0"	26'-0"	28'-0"	30'-0"	32'-0"	
SINGLE WIDE UNITS	6'-0"	3	3	3	N/A	N/A	N/A	N/A	N/A	N/A	N/A	N/A	N/A	N/A
	7'-11 1/2"	3	3	3	4	4	4	5	5	5	N.A.	N.A.	N.A.	N.A.
	9'-11 1/2"	2	3	3	3	3	4	4	4	4	5	5	5	N.A.
	11'-0"	2	3	3	3	3	4	4	4	4	5	5	5	5

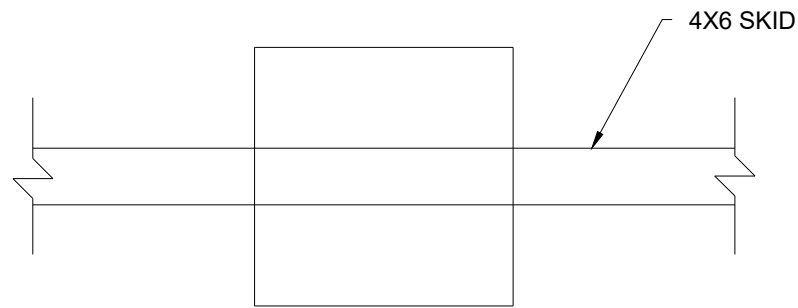

1 16"X16"X4" PAD DETAIL
F-6 SCALE: N.T.S.

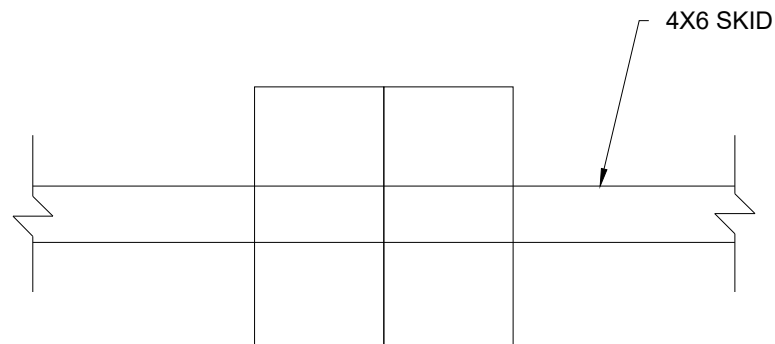

2 (2) 16"X8"X4" PAD DETAIL
F-6 SCALE: N.T.S.

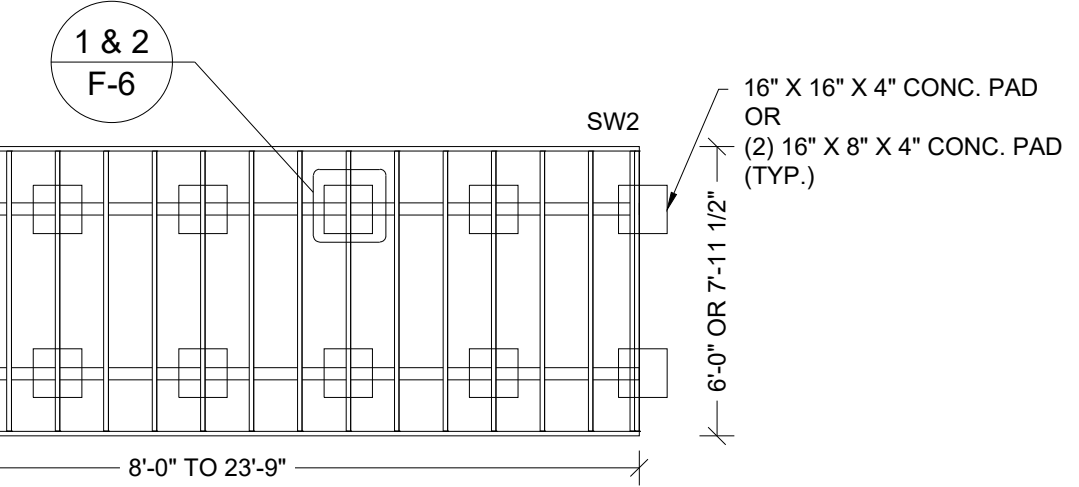
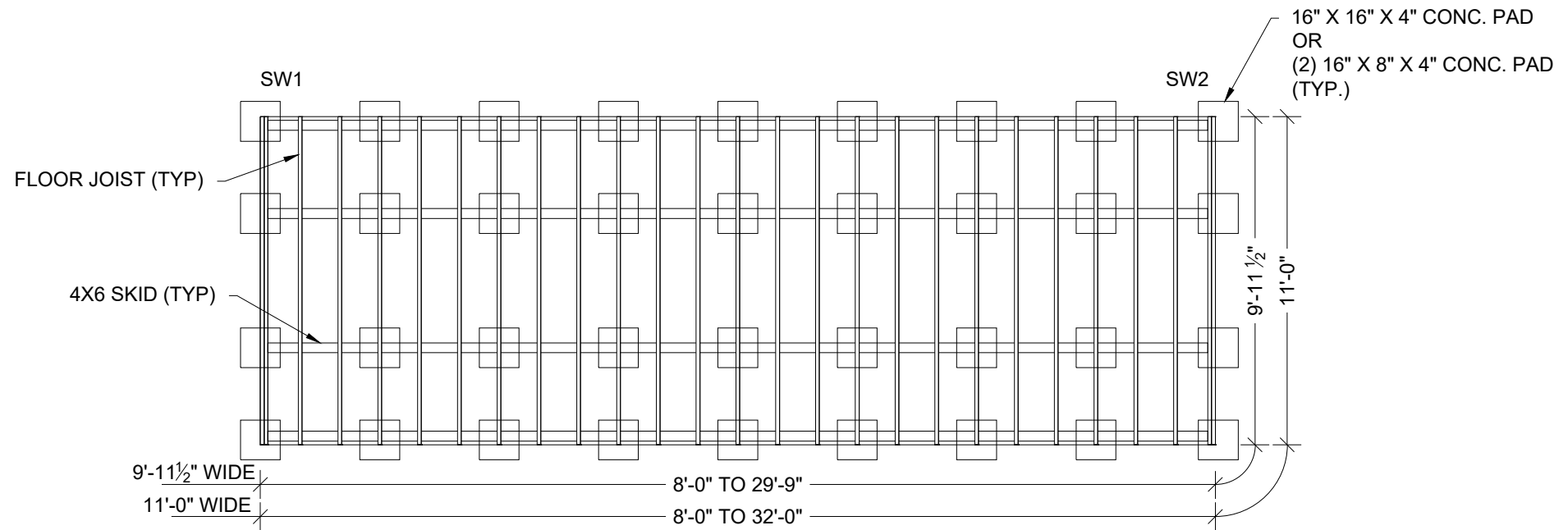

3 PAD LOCATION PLAN
F-6 SCALE: N.T.S.

16" X 16" X 4" CONC. PAD OR (2) 16" X 8" X 4" CONC. PAD (TYP.)

16" X 16" X 4" CONC. PAD OR (2) 16" X 8" X 4" CONC. PAD (TYP.)

Engineer: Kent Bice
FL License #: 50421
COA# 30468



04/12/18

1552 6TH ST., WINTER HAVEN, FL 33880
(863)865-6502

OPTIONAL PAD DETAILS

DATE: 04/10/18 DRAWN BY: RD
SCALE: AS NOTED CHECKED BY: KMB

SHEET:

F-6

SHEET 6 OF 6

THESE PLANS WERE DESIGNED IN ACCORDANCE WITH THE 6TH EDITION, 2017 FLORIDA BUILDING CODE.